

HIKVISION

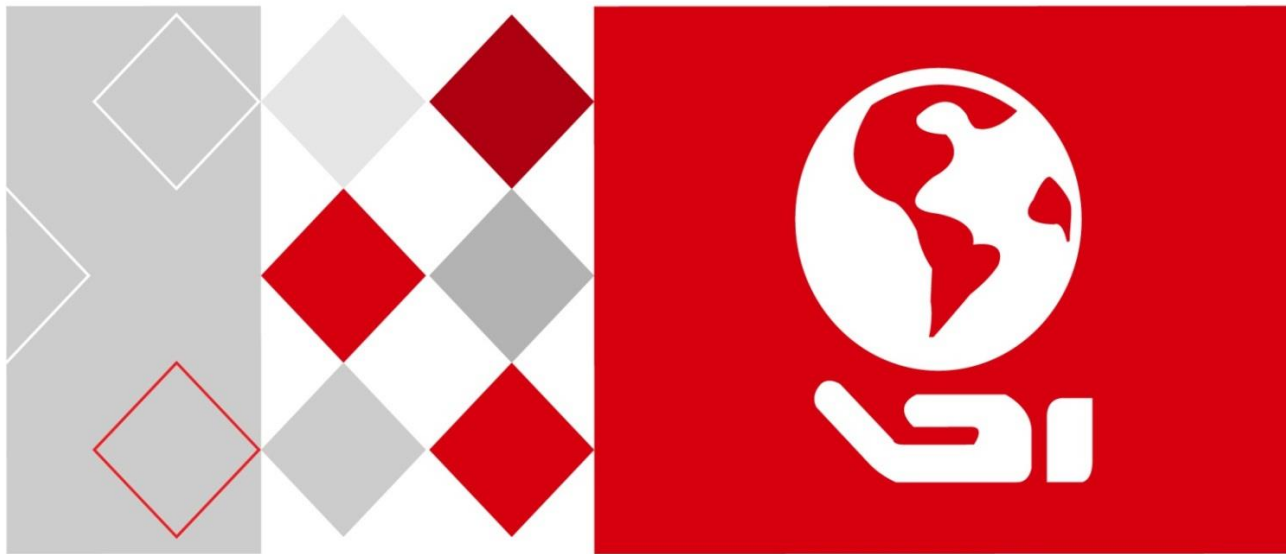

Machine Vision Line Scan GigE Camera

User Manual

User Manual

COPYRIGHT ©2015 Hangzhou Hikvision Digital Technology Co., Ltd.

ALL RIGHTS RESERVED.

Any and all information, including, among others, wordings, pictures, graphs are the properties of Hangzhou Hikvision Digital Technology Co., Ltd. or its subsidiaries (hereinafter referred to be “Hikvision”). This user manual (hereinafter referred to be “the Manual”) cannot be reproduced, changed, translated, or distributed, partially or wholly, by any means, without the prior written permission of Hikvision. Unless otherwise stipulated, Hikvision does not make any warranties, guarantees or representations, express or implied, regarding to the Manual.

About this Manual

This Manual is applicable to Machine Vision Line Scan GigE Camera.

The Manual includes instructions for using and managing the product. Pictures, charts, images and all other information hereinafter are for description and explanation only. The information contained in the Manual is subject to change, without notice, due to firmware updates or other reasons. Please find the latest version in the company website (<http://overseas.hikvision.com/en/>).

Please use this user manual under the guidance of professionals.

Trademarks Acknowledgement

HIKVISION and other Hikvision’s trademarks and logos are the properties of Hikvision in various jurisdictions. Other trademarks and logos mentioned below are the properties of their respective owners.

Legal Disclaimer

TO THE MAXIMUM EXTENT PERMITTED BY APPLICABLE LAW, THE PRODUCT DESCRIBED, WITH ITS HARDWARE, SOFTWARE AND FIRMWARE, IS PROVIDED “AS IS”, WITH ALL FAULTS AND ERRORS, AND HIKVISION MAKES NO WARRANTIES, EXPRESS OR IMPLIED, INCLUDING WITHOUT LIMITATION, MERCHANTABILITY, SATISFACTORY QUALITY, FITNESS FOR A PARTICULAR PURPOSE, AND NON-INFRINGEMENT OF THIRD PARTY. IN NO EVENT WILL HIKVISION, ITS DIRECTORS, OFFICERS, EMPLOYEES, OR AGENTS BE LIABLE TO YOU FOR ANY SPECIAL, CONSEQUENTIAL, INCIDENTAL, OR INDIRECT DAMAGES, INCLUDING, AMONG OTHERS, DAMAGES FOR LOSS OF BUSINESS PROFITS, BUSINESS INTERRUPTION, OR LOSS OF DATA OR DOCUMENTATION, IN CONNECTION WITH THE USE OF THIS PRODUCT, EVEN IF HIKVISION HAS BEEN ADVISED OF THE POSSIBILITY

OF SUCH DAMAGES.

REGARDING TO THE PRODUCT WITH INTERNET ACCESS, THE USE OF PRODUCT SHALL BE WHOLLY AT YOUR OWN RISKS. HIKVISION SHALL NOT TAKE ANY RESPONSIBILITIES FOR ABNORMAL OPERATION, PRIVACY LEAKAGE OR OTHER DAMAGES RESULTING FROM CYBER ATTACK, HACKER ATTACK, VIRUS INSPECTION, OR OTHER INTERNET SECURITY RISKS; HOWEVER, HIKVISION WILL PROVIDE TIMELY TECHNICAL SUPPORT IF REQUIRED.

SURVEILLANCE LAWS VARY BY JURISDICTION. PLEASE CHECK ALL RELEVANT LAWS IN YOUR JURISDICTION BEFORE USING THIS PRODUCT IN ORDER TO ENSURE THAT YOUR USE CONFORMS THE APPLICABLE LAW. HIKVISION SHALL NOT BE LIABLE IN THE EVENT THAT THIS PRODUCT IS USED WITH ILLEGITIMATE PURPOSES. IN THE EVENT OF ANY CONFLICTS BETWEEN THIS MANUAL AND THE APPLICABLE LAW, THE LATER PREVAILS.

Regulatory Information

FCC Information

FCC compliance: This equipment has been tested and found to comply with the limits for a digital device, pursuant to part 15 of the FCC Rules. These limits are designed to provide reasonable protection against harmful interference when the equipment is operated in a commercial environment. This equipment generates, uses, and can radiate radio frequency energy and, if not installed and used in accordance with the instruction manual, may cause harmful interference to radio communications. Operation of this equipment in a residential area is likely to cause harmful interference in which case the user will be required to correct the interference at his own expense.

FCC Conditions

This device complies with part 15 of the FCC Rules. Operation is subject to the following two conditions:

1. This device may not cause harmful interference.
2. This device must accept any interference received, including interference that may cause undesired operation.

EU Conformity Statement



This product and - if applicable - the supplied accessories too are marked with "CE" and comply therefore with the applicable harmonized European standards listed under the EMC Directive 2004/108/EC, the RoHS Directive 2011/65/EU.



2012/19/EU (WEEE directive): Products marked with this symbol cannot be disposed of as unsorted municipal waste in the European Union. For proper recycling, return this product to your local supplier upon the purchase of equivalent new equipment, or dispose of it at designated collection points. For more information see: www.recyclethis.info.

Safety Instruction

These instructions are intended to ensure that the user can use the product correctly to avoid danger or property loss.

The precaution measure is divided into ‘Warnings’ and ‘Cautions’:

Warnings: Serious injury or death may be caused if any of these warnings are neglected.

Cautions: Injury or equipment damage may be caused if any of these cautions are neglected.

Warnings Follow these safeguards to prevent serious injury or death.	Cautions Follow these precautions to prevent potential injury or material damage.



Warnings:

- Please adopt the power adapter which can meet the safety extra low voltage (SELV) standard. And source with 12 VDC (depending on models) according to the IEC60950-1 and Limited Power Source standard.
- To reduce the risk of fire or electrical shock, do not expose this product to rain or moisture.
- This installation should be made by a qualified service person and should conform to all the local codes.
- Please install blackouts equipment into the power supply circuit for convenient supply interruption.
- Please make sure that the ceiling can support more than 50(N) Newton gravities if the camera is fixed to the ceiling.
- If the product does not work properly, please contact your dealer or the nearest service center. Never attempt to disassemble the camera yourself. (We shall not assume any responsibility for problems caused by unauthorized repair or maintenance.)



Cautions:

- Make sure the power supply voltage is correct before using the camera.
- Do not drop the camera or subject it to physical shock.
- Do not touch sensor modules with fingers. If cleaning is necessary, use a clean cloth with a bit of ethanol and wipe it gently. If the camera will not be used for an extended period of time, put on the lens cap to protect the sensor from dirt.
- Do not aim the camera lens at the strong light such as sun or incandescent lamp. The strong light can cause fatal damage to the camera.
- The sensor may be burned out by a laser beam, so when any laser equipment is being used, make sure that the surface of the sensor not be exposed to the laser beam.
- Do not place the camera in extremely hot, cold temperatures (the operating temperature should be between -0°C to 50°C), dusty or damp environment, and do not expose it to high electromagnetic radiation.
- To avoid heat accumulation, ensure there is good ventilation to the device.
- Keep the camera away from water and any liquids.
- While shipping, pack the camera in its original, or equivalent, packing materials. Or packing the same texture.
- Improper use or replacement of the battery may result in hazard of explosion. Please use the manufacturer recommended battery type.

Table of Contents

Chapter 1 Product Introduction.....	8
1.1 Product description	8
1.2 Key Features	8
1.3 Specifications	9
1.3.1 MV-CL020-40GM Specification	9
1.3.2 MV-CL020-40GM Response Curve	10
1.3.3 MV-CL020-41GC Specification	11
1.3.4 MV-CL020-41GC Response Curve	12
1.4 Camera Physical Interfaces.....	12
1.4.1 Camera Dimension	12
1.4.2 Rear Panel Introduction	13
1.4.3 Power and I/O Interface Introduction.....	14
1.4.4 Installation Accessories	15
Chapter 2 Camera Installation and Configuration.....	16
2.1 Installing the Camera	16
2.2 Network Configuration.....	16
2.2.1 Camera IP Configuration	16
2.2.2 Local Network Configuration	17
2.3 Camera Configuration	19
2.3.1 Setting via Attribute Tree	19
2.3.2 Setting via Menu Bar	21
Chapter 3 Functions	23
3.1 Device Control	23
3.2 Image Format and Frame Rate.....	24
3.2.1 Camera Data Format	24
3.2.2 Line Rate.....	24
3.2.3 ROI Setting.....	25
3.3 Imaging Parameter Setting.....	26
3.3.1 Exposure Time	26
3.3.2 Gain Control	26
3.3.3 Look Up Table (LUT)	27

3.3.4 Gamma Correction	27
3.3.5 Image Reverse	28
3.3.6 White Balance	29
3.3.7 Region Setting of Auto Functions	30
3.3.8 Test Pattern	30
3.4 Image Acquisition and Transmission	33
3.4.1 Internal Trigger Mode	33
3.4.2 External Trigger Signal and Working Mode	34
3.5 Strobe Output	36
3.6 Acquisition Mode under External Trigger	36
3.6.1 Acquisition Start and Stop	36
3.6.2 Acquisition Mode	37
3.6.3 Trigger Mode	37
3.7 Encoder Control	40
3.7.1 Source Signal	40
3.7.2 Axis encoder control parameters	41
3.8 Frequency Converter Control	42
3.9 I/O Electrical Character	43
3.9.1 Practical Wiring	43
3.9.2 Line0/Line3 Input Circuit	44
3.9.3 Line1/Line4 Output Circuit	46
3.9.4 Line2 Configurable Bi-direction I/O Circuit	48
3.10 Transport Layer Control	50
3.10.1 DHCP and Persistent IP	50
3.10.2 Efficient Bandwidth and Setting	50
3.10.3 Parameters Saving and Loading	51
3.10.4 Embedded Information	52
3.11 Firmware Updating	54
Chapter 4 Troubleshooting	56
4.1 Indicator Status Definition	56
4.2 Indicator Status Description	56
4.3 FAQ	57

Chapter 1 Product Introduction

1.1 Product description

The Machine Vision Camera is an image capturing device capable of real-time transmission of uncompressed image through a gigabit Ethernet interface. Remote image capturing and camera control, for example, the operating mode and the image parameters adjustment, are supported by client software.

1.2 Key Features

- The gigabit Ethernet interface provides the bandwidth of 1 Gbps and reaches the maximum transmission distance of 100 meters.
- 128 MB onboard memory stores images for burst transmission and retransmission.
- Supports AEC (automatic exposure control), LUT, Gamma Correction, etc..
- Use hardware external trigger or software trigger to synchronize several cameras or cameras with external devices.
- Supports image capturing with different exposure modes.
- Compatible with GigE Vision Protocol (V1.2) and third-party software.

Note: The functions in this manual are for reference only and may differ from the devices.

1.3 Specifications

1.3.1 MV-CL020-40GM Specification

Table 1-1 MV-CL020-40GM Specification

Model	MV-CL020-40GM
Parameters	2k Pixels Line Scan Gigabit Ethernet Camera
Camera	
Resolution	2048*1
Pixel Size	7 μ m
Line Rate	1Hz~51kHz
ADC Bites	12 bit
Bit Depth	8,10,12 bit
Dynamic Range	>60dB
SNR	>40dB
ISP	Gamma , lookup table
Gamma Correction	0 to 4.00 , programmable lookup table
Binning	1/2/3/4binning
ROI	1 ROI
Mirroring	Horizontal Mirroring
PRNU Correction	Supported
Gain Control	Manual Set
Gain Range	0~11.7dB
Min Exp.Time	2 μ s
Shutter mode	Support fixed exposure time and trigger pulse width control
Data Interface	Gigabit Ethernet
Throughout Data Rate	100/1000 Mbits
GPIO	12-pin Hirose Connector: 2 RS422 Inputs, 1 Single-end Input, 2 RS422 Outputs
External trigger mode	Line trigger and frame trigger mode

Sync signal mode	Software Trigger or Hardware External Trigger
Image Buffer	128MB
Parameters storage area	4 groups of parameter storage area, including user set parameters, flat field parameters
Data Format	Mono 8/10/12/10p/12p
General	
Power	<4W@12VDC, Voltage 5~15V; PoE
Temperature	Working Temperature 0~50°C, Storage Temperature -30~70°C
Dimension	62mm*62mm*37.5mm
Weight	170g
Lens Interface	M42*1.0, M42*1.0, Back focus distance 12mm F mount or C mount lens supported with lens adapter
Software	MVS or Third-Party Software supporting GigE Vision Protocol
Operating System	Windows XP/7/8 32/64bits
Compliance	GigE Vision V1.2
Certification	CE, FCC, RoHS

1.3.2 MV-CL020-40GM Response Curve

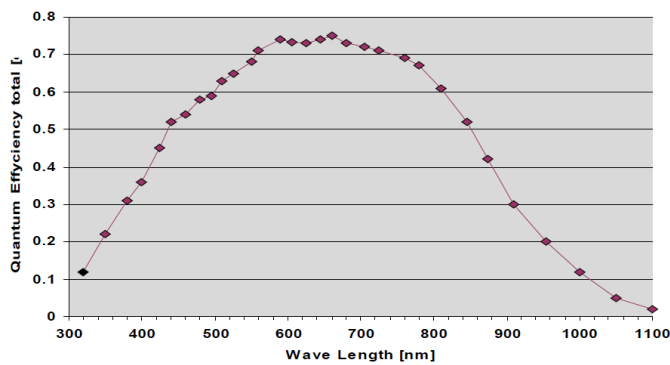

Figure 1-1 MV-CL020-40GM Quantum Efficiency

1.3.3 MV-CL020-41GC Specification

Table 1-2 MV-CL020-41GC Specification

Model Parameters	MV-CL020-41GC 2k Pixels Line Scan Gigabit Ethernet Camera
Camera	
Resolution	2048*2
Pixel Size	7 μ m
Line Rate	1Hz~26kHz
ADC Bites	12 bit
Bit Depth	8,10,12 bit
Dynamic Range	>60dB
SNR	>40dB
ISP	Gamma , lookup table
Gamma Correction	0 to 4.00 , programmable lookup table
ROI	2 ROI
PRNU Correction	Supported
Gain Control	Auto and Manual Set
Gain Range	0~7.9dB
Min Exp.Time	2 μ s
Shutter mode	Support auto exposure, fixed exposure time and trigger pulse width control
Data Interface	Gigabit Ethernet
Throughout Data Rate	100/1000 Mbits
GPIO	12-pin Hirose Connector: 2 RS422 Inputs, 1 Single-end Input, 2 RS422 Outputs
External trigger mode	Line trigger and frame trigger mode
Sync signal mode	Software Trigger or Hardware External Trigger
Image Buffer	128MB
Parameters storage area	4 groups of parameter storage area, including user set parameters, flat field parameters

General	
Power	<4W@12VDC, Voltage 5~15V; PoE
Temperature	Working Temperature 0~50°C, Storage Temperature -30~70°C
Dimension	62mm*62mm*37.5mm
Weight	170g
Lens Interface	M42*1.0, M42*1.0, Back focus distance 12mm F mount or C mount lens supported with lens adapter
Software	MVS or Third-Party Software supporting GigE Vision Protocol
Operating System	Windows XP/7/8 32/64bits
Compliance	GigE Vision V1.2
Certification	CE, FCC, RoHS

1.3.4 MV-CL020-41GC Response Curve

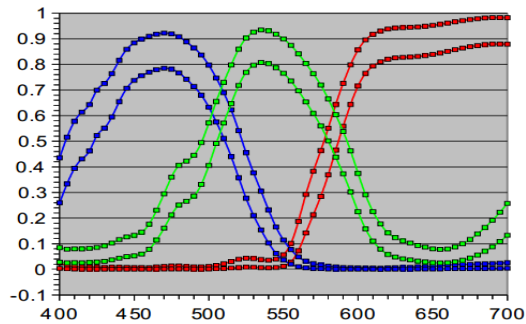

Figure 1-2 MV-CL020-41GC Quantum Efficiency

Note:

The response curve data is provided by the chip manufacture.

1.4 Camera Physical Interfaces

1.4.1 Camera Dimension

The mechanical dimension of the MV-CL020-40GM, MV-CL020-41GC is shown below. The camera should be installed with M4*6 screws.

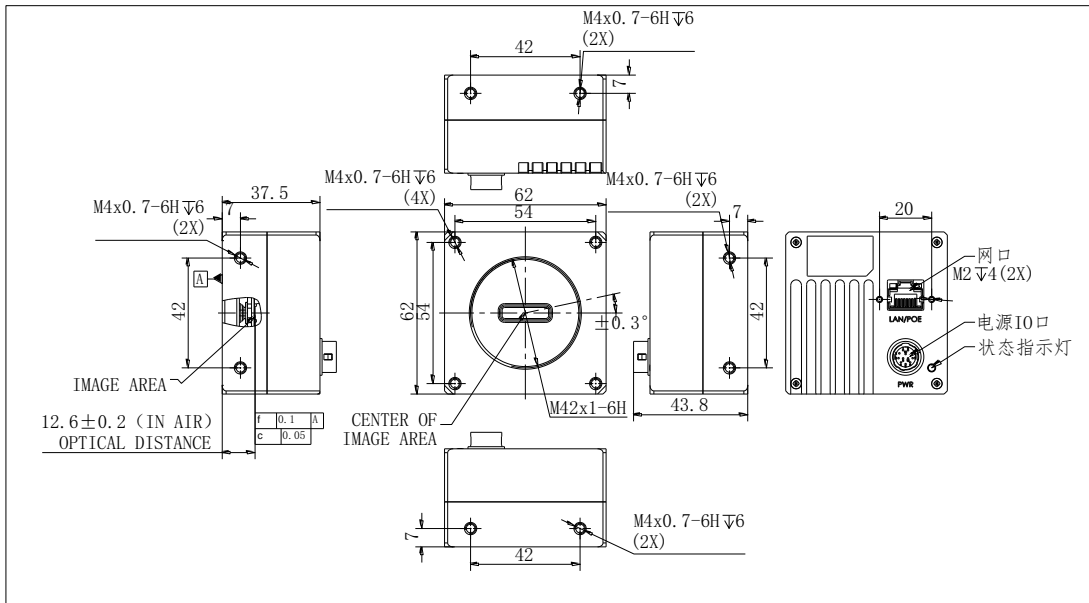

Figure 1-3 Dimension

Note:

The camera adopts the M42-Mount lens interface, and comes with a M42 to C adapter ring, if other interfaces of lens used, you need to use the appropriate adapter ring.

1.4.2 Rear Panel Introduction

The rear panel of the line scan camera is shown in the figure below, including a standard RJ45 Gigabit Ethernet cable interface, a 12-pin power supply and I / O input interface, and a camera work status indicator. There are two M2 standard locking screw holes on both sides of the network interface, which are used to fix the network cable to reduce the loose of the network cable caused by the vibration.

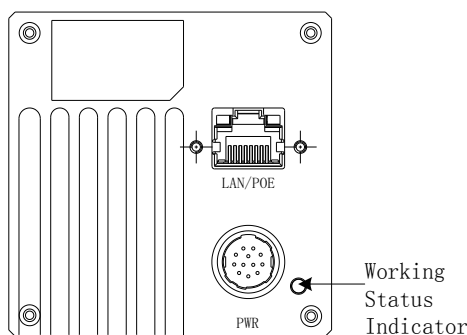

Figure 1-4 Rear Panel

Table 1-3 Description of the Rear Panel

No.	Description
1	RJ45 gigabit Ethernet interface

2	M2 screw holes for network cable securing
3	12-pin power and I/O interface
4	Status indicator LED

1.4.3 Power and I/O Interface Introduction

The description of the 12-pin power and I/O connector is shown in the table below. TTL voltage level that Differential Input required is 5V, and Bidirectional IO voltage level is 5~30V.

Table 1-4 Power and I/O Interface Description

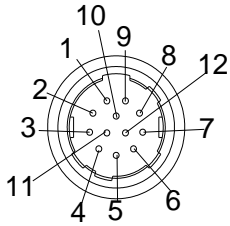
	PIN	Signal	I/O Type	Description
	1	GND	Input	Power Ground
	2	DC_PWR	Input	12V VCC+
	3	IO_IN0_P	Input	Differential Input 0+
	4	IO_IN0_N	Input	Differential Input 0-
	5	GND	Input	Signal Ground
	6	IO_IN1_P	Input	Differential Input 1+
	7	IO_IN1_N	Input	Differential Input 1-
	8	IO2	Input or Output	Bidirectional IO
	9	IO_OUT0_P	Output	Differential Output 0+
	10	IO_OUT0_N	Output	Differential Output 0-
	11	IO_OUT1_P	Output	Differential Output1+
	12	IO_OUT1_N	Output	Differential Output1-

Note:

The camera IO are set to Line0 ~ Line4, and the corresponding relationship with the camera hardware is shown in Table 1-5.

Table 1-5 IO Interface List

Hardware PIN	Software IO	Note
IO_IN0	Line0	Input
IO_IN1	Line3	Input
IO2	Line2	Configured as Input or Output
IO_OUT0	Line1	Output
IO_OUT1	Line4	Output

1.4.4 Installation Accessories

Prepare the installation accessories listed below before you install the machine vision camera.

Table 1-6 Accessory List

No.	Accessory Name	Quantity	Description
1	Camera	1	The machine vision camera
2	Adapter ring (M42 to C interface)	1	Other interface lens should be equipped with corresponding adapter ring
3	Power I/O cable	1	The 12-pin cable (Included) or extension cable (Not included)
4	DC switching power supplies	1	12V DC power adapter (Min. 1A)
5	Ethernet cable with proper length	1	CAT-5e or CAT-6 Ethernet cable
6	Lens (Optional)	1	C-Mount Lens (Other interface)

Chapter 2 Camera Installation and Configuration

2.1 Installing the Camera

Steps:

1. Unpack the camera package and install the lens (optional) to the camera body by rotating the lens clockwise.
2. Fix the camera to the desired position.
3. Use CAT-5e or CAT-6 network cable to connect the camera with a switch or a network card.
4. Choose a power supply method.
 - Direct supply: Use the supplied cord with a 12-pin power and I/O interface to connect the camera to a power adapter (DC 12V for the camera).
 - PoE (Power over Ethernet): Use a network cable to connect the camera to a switch or a network card that supports PoE function.

Note: The machine vision network camera adopts a gigabit network interface. To guarantee the bandwidth for real-time image transmission, you need to use a CAT-5e or CAT-6 network cable.

2.2 Network Configuration

Purpose:

Before using the camera, you need to configure the IP address of the camera. The IP addresses of the camera and the local computer should belong to the same network segment. You can use the ping command on the local computer to test the network connectivity.

Before you start:

Download the MVS control client from the website and install it on your PC. Refer to the *User Manual of MVS Client Software* for details.

2.2.1 Camera IP Configuration

You can use the client software to complete network configuration for the camera.

Steps:

1. Device Status detecting.
2. Effective IP configuration.
3. Save the IP address to the camera in the static storage.

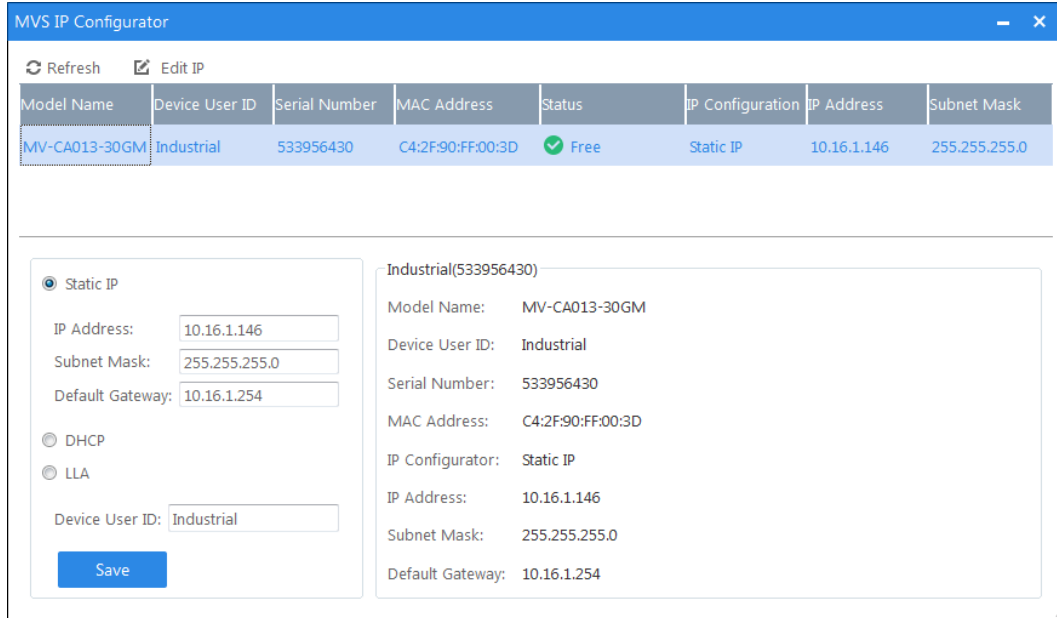

Figure 2-1 Camera Network Parameters Setting

2.2.2 Local Network Configuration

Steps:

1. Click Start -> Control Panel -> Network and Internet -> Network and Sharing Center -> Change adapter settings, select the network connection and click Properties.
2. Double click the TCP protocol, and you can set select **Obtain an IP address automatically**.
3. (Optional) You can also select **Use the following IP address**, and set the IP address as the same subnet with the camera.

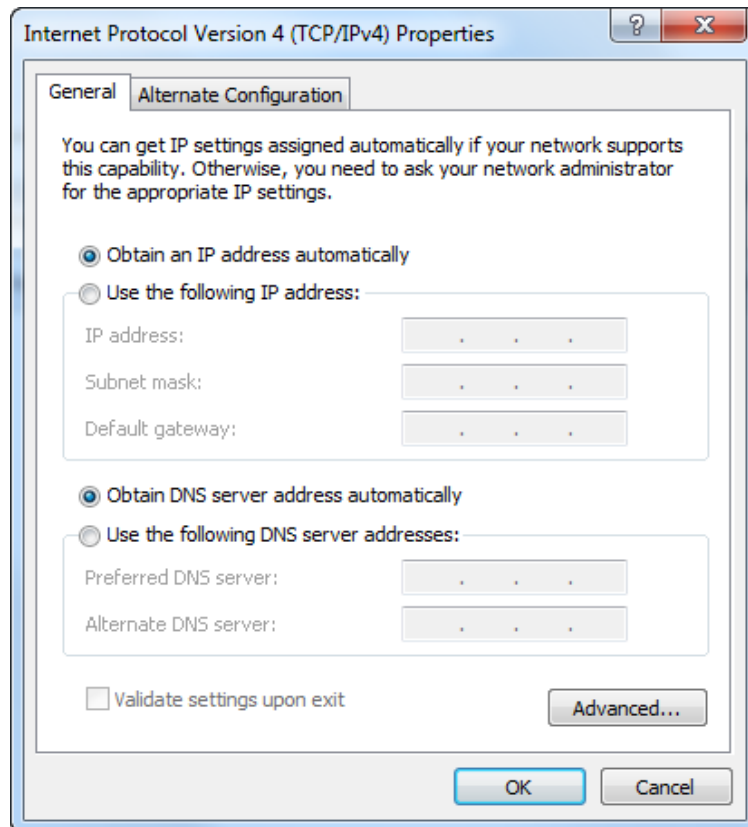

Figure 2-2 IP Address Setting

4. Click **OK** to save the settings.
5. You also need to enable the jumbo frame of the NIC. For different operating systems, the path to setting the jumbo frame may be different. Here we take Windows 7 as an example.
 - 1) Click Start -> Control Panel -> Hardware and Sound -> Device Manager -> Network adapters, double click the NIC to enter its properties interface.
 - 2) Click **Advanced** tab.
 - 3) Select **Jumbo Frame** from the property list and select the value as **9KB MTU**.
 - 4) Click **OK** to save the settings.

Note: Jumbo frame is not supported by some types of NIC. We recommend you to use the NIC which supports jumbo frame for better image transmission.

2.3 Camera Configuration

Note: Configure the camera via the control client. There two methods available: setting via the attribute tree or via the menu bar.

2.3.1 Setting via Attribute Tree

The software can read the XML file of camera attributes and display it in tree format.

Steps:

1. Double click the MVS icon to open the client software. The main user interface and the description of the client software are shown in Figure 2-13 and Table 2-1.

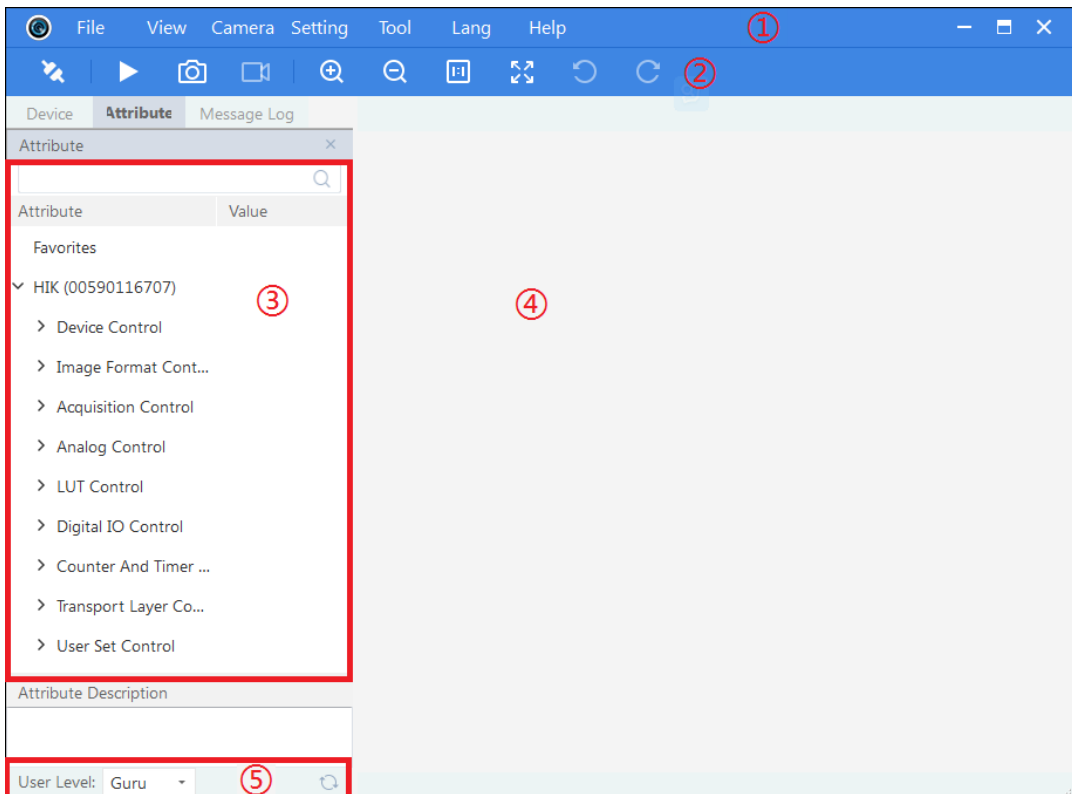

Figure 2-3 Main User Interface of the Client Software

Table 2-1 Description of the Main User Interface

No.	Area Name	Description
1	Menu Bar	Function modules including File, View, Camera, Settings, Tools, and Help.

2	Control Toolbar	Control the image of live view including starting/stopping live view, zooming in/out, recording, capturing, etc.
3	Device and Attribute Tree	Display the online machine vision cameras in the same LAN with the client software and the device attributes.
4	User Level Area	Switch the user level quickly as beginner, expert or guru.
5	Live View Area	View the live video of the selected machine vision camera.

Note: For detailed information, refer the *User Manual of MVS Control Client*.

2. Double click the camera on the device list in Device and Attribute Tree area.
3. Click the **Attributes** tab to enter the camera attribute page.

Note: You can switch the user level as Beginner, Expert or Guru which displays different camera attributes. For Guru Level, it provides the most comprehensive camera attributes for professional use. Here we take Guru Level as an example.

4. Click the  icon before each attribute to view and edit the details.

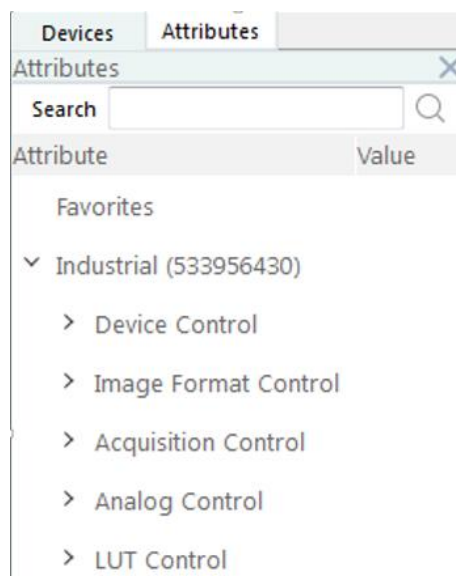

Figure 2-4 Attribute Page

- **Device Control:** In the Device Control attribute, you can view the camera details include device type, version, manufacturer details, device ID, device alias, device temperature, etc. You can modify the alias and reset the device.
- **Image Format Control:** In the Image Format Control attribute, you can view the live view image width and height, pixel size, etc. You can modify the image reverse status, test pattern and the embedded information, etc.
- **Acquisition Control:** In the Acquisition Control attribute, you can set the trigger mode, trigger source, exposure details, etc.
- **Analog Control:** In the Analog Control attribute, you can adjust analog gain, black level, brightness, gamma, sharpness, AOI, etc.
- **LUT Control:** In the LUT Control attribute, you can view the user lookup table and set the LUT index and value.
- **Shading Control:** User can set the brightness uniformity of the corrected image.
- **Encoder Control:** External trigger source signal can be converted into the internal required signal.
- **Frequency Converter:** Can convert different frequencies of the external signal into a signal of internal accept frequency.
- **Digital IO Control:** In the Digital IO Control attribute, you can manage the digital input and output.
- **Transport Layer Control:** In the Transport Layer Control attribute, you can set the parameters of transport layer of the camera.
- **User Set Control:** In the User Set Control attribute, you can save or load the parameter configuration set by users. You can set the default parameter when running the software.

2.3.2 Setting via Menu Bar

You can set the camera attribute via the menu bar which classifies the camera attributes.

Click **Settings** -> **Attributes** to enter the attributes setting interface.

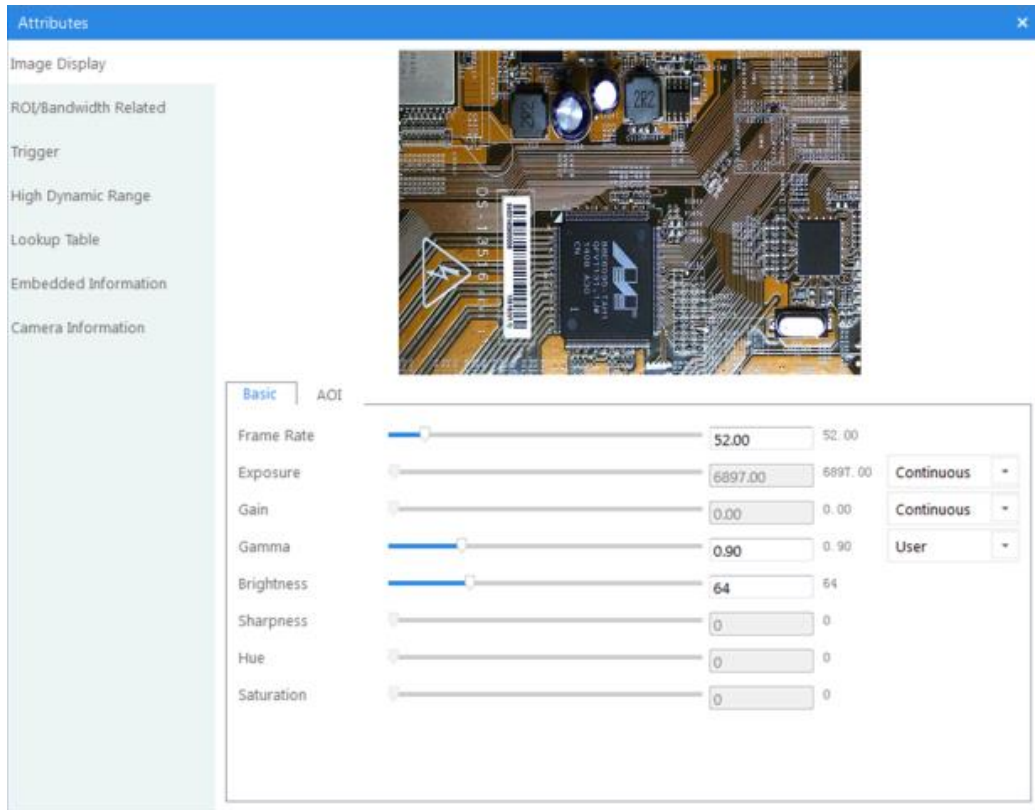

Figure 2-5 Setting via Menu Bar

You can set the image display, ROI, bandwidth, trigger mode, high dynamic range, lookup table, embedded information and camera information.

Note: Functions and Attributes of machine vision cameras may be different among different camera models. Refer to the actual user interface and the user manual of the camera for detailed information.

Chapter 3 Functions

3.1 Device Control

Run client software and click Device Control. You will see the device type, the version information, the device serial number and so on. Input the device name in Device User ID as shown in Figure 3-1.

Device Control	
Device Type	Transmitter
Device Scan Type	Linescan
Device Vendor Name	hikvision
Device Model Name	MV-CL020-40GM
Device Manufacturer Info	hikvision
Device Version	V1.3.0 151109A
Device Firmware Version	V1.3.0 151109_A151027
Device Serial Number	201508263
Device ID	201508263
Device User ID	HBK
Device Uptime(s)	2337
Board Device Type	0x2000
Device Connection Sele...	0

Figure 3-1 Device Name Modification

You can turn on the heartbeat detection mechanism, reset the device and view the device temperature in Device Control, as shown in Figure 3-2.

Device Link Selector	0
Device Link Speed(Mbps)	1000
Device Link Connection Count	1
Device Link Heartbeat Mode	On
Device Command Timeout	0.00000
Device Stream Channel Count	1
Device Stream Channel Selector	0
Device Stream Channel Type	Transmitter
Device Stream Channel Link	0:
Device Stream Channel Endianness	Little
Device Stream Channel Packet Size(B)	1484
Device Event Channel Count	0
Device Character Set	UTF 8
Device Reset	Execute
Device Max Throughput(bps)	761300000

Figure 3-2 Device Information

3.2 Image Format and Frame Rate

Support different image format and customized ROI setting. The specified ROI will increase the image frame rate in some models.

Note: The following figures are for reference only. The actual format depends on the camera’s supported formats.

3.2.1 Camera Data Format

The supporting pixel format of MV-CL camera is shown in Table 3-1.

Table 3-1 Data Format Table

Format	Mono 8	Mono 10/10p	Mono12/12p	RGB 8	Baye r 8	Bayer 10/10p	Bayer 12/12p	YUV 422 8	YUV 422 8 UYVY
MV-CL020-40GM	Y	Y	Y	---	---	---	---	---	---
MV-CL020-41GC	Y	---	---	Y	Y	Y	Y	Y	Y

Note: YUV 422 8 is the default output data format for color camera. Mono8 is the default output format for black and white camera. “Y” means support and “---” means not support.

Click Image Format Control in the attribute list and select Pixel Format. You will find the supported pixel format. Choose the appropriate data output format as shown in Figure 3-3 and finish setting.

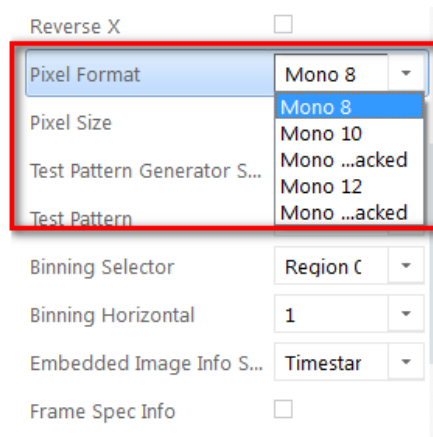

Figure 3-3 Pixel Format Setting

3.2.2 Line Rate

The network transmission bandwidth, pixel format and output ROI resolution decides the maximum camera line rate. Please refer to the frame rate formula when setting ROI.

Click Acquisition Control in the attribute list and select Acquisition Line Rate. Input available frame rate as shown in Figure 3-4 and finish setting.

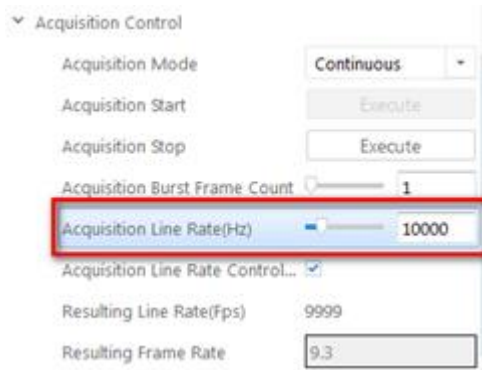

Figure 3-4 Line Rate Setting

The following three factors decide the maximum camera line rate:

- Line Readout time: the less the readout time and the higher the line rate.
- Exposure time: the less the exposure time, the higher the line rate.
- Bandwidth: the wider the bandwidth, the higher the line rate.

The frame rate of the camera is proportional to the line frequency, and is inversely proportional to the height of the image area, $Fps=Lps/Image\ Height$.

3.2.3 ROI Setting

The camera can output ROI images depending on your requirements. ROI setting can decrease the data transmission bandwidth and increase the camera frame rate. Click Image Format Control and move. Select Width and Height. Adjust the ROI on the right side. The value in the Offset X and the Offset Y refer to the ROI starting point at the top left corner. The following figure shows the ROI setting.

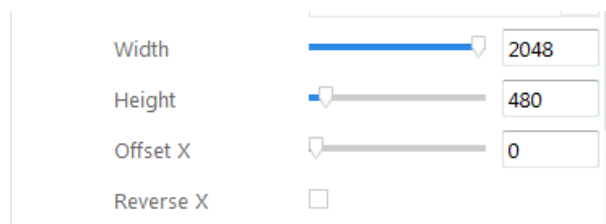

Figure 3-5 ROI Setting

Note:

- For Bandwidth and Payload Size, please refer to Chapter 3.10.
- Offset Y of line scan camera cannot be set.

3.3 Imaging Parameter Setting

3.3.1 Exposure Time

Please refer to the camera technical index to acquire the supported exposure time. Line scan camera exposure control can be manual mode, also supports auto exposure mode. Users can set the value of the exposure time according to the actual needs, can be set to a range of 2 ~ 10000 us.

Note:

When Trigger Mode is setting as line trigger, the exposure time can be set manually or by the external pulse width. Refer to Section 3.6.3 Line Trigger Descriptions.

Click Acquisition Control in the attribute list. Select Exposure Time, input available parameter to the numeric field, as shown in Figure 3-6.

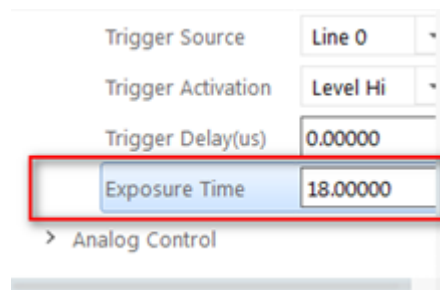

Figure 3-6 Exposure Control

3.3.2 Gain Control

Gain control of mono line scan camera is manual mode, while color line scan camera can be selected as automatic auto gain control. Users can set the gain value according to the actual demand. The setting range of mono camera gain is 0 ~ 11.7dB. The color camera gain can be set to 0 ~ 7.9dB. If the gain needs to set a larger range, tick the ADC Gain x4 Enable, and can be in an increase of 12dB on the basis of the original set value.

Click Analog Control in the attribute list. Find Gain. Input available parameter in the numeric field and finish setting, as shown in Figure 3-7.

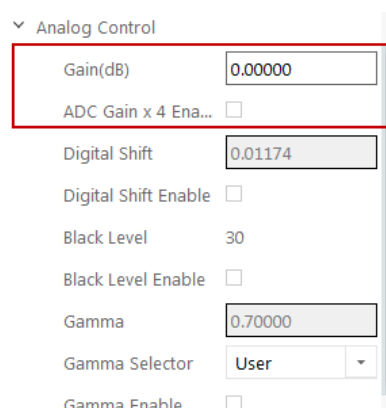

Figure 3-7 Gain Control

Note:

Brightness and noise increases when Gain increases.

3.3.3 Look Up Table (LUT)

LUT is the grey level mapping table. You can change the grey level in your interested regions. The operation can be linearity curve or custom mapping curve. LUT and Gamma are mutually exclusive.

Set the user mode to Guru Mode. Click LUT Enable and adjust the parameters, as shown in Figure 3-8.

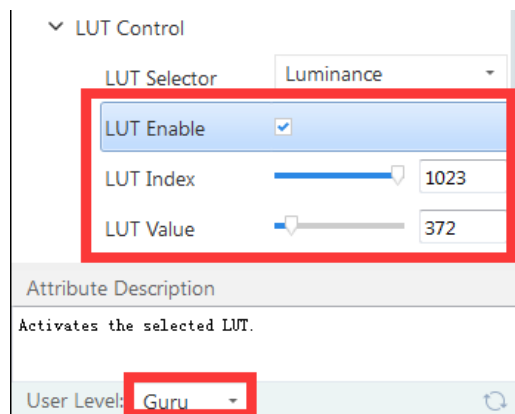

Figure 3-8 LUT Setting

3.3.4 Gamma Correction

The camera supports Gamma Correction. Normally, the output of the camera chip and the number of photon that the sensor (on the chip) received are linear. And Gamma Correction provides a non-linear output. If the Gamma value is between 0.5 and 1, the image brightness decreases while the brightness of the dark area increases. If the Gamma value is between 1 and 4, the image brightness increases while the brightness of the dark area decreases.

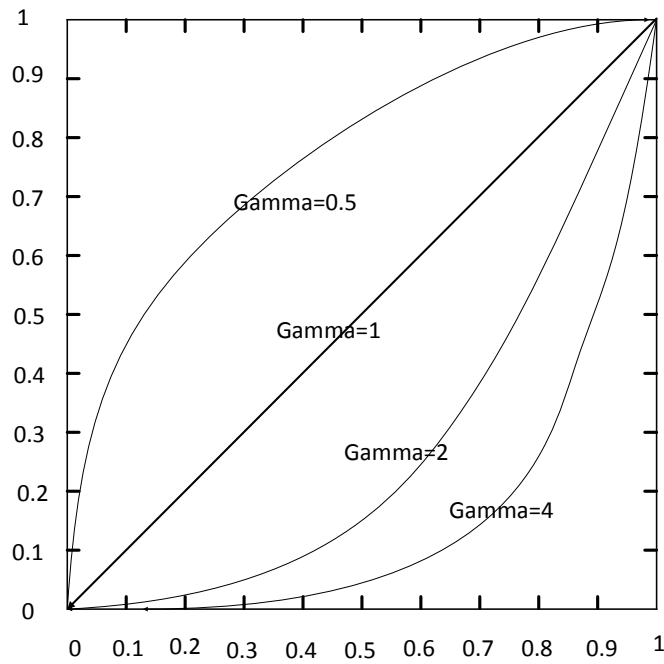

Figure 3-9 Gamma Curve

Click Analog Control in the attribute list. Select Gamma and Gamma Selector and set the parameter as shown in Figure 3-10.

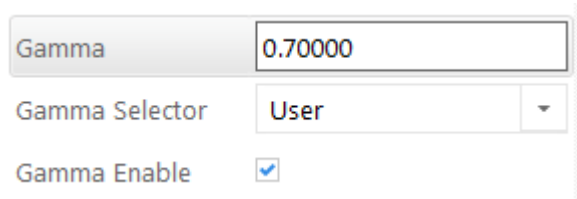

Figure 3-10 Gamma Setting

Note:

Default value of Gamma is 0.7.

3.3.5 Image Reverse

The camera supports image horizontal mirroring. Open the mirroring function to gain the horizontal mirroring image. Click Image Format Control. Tick Reverse X (horizontal) according to your preference, as shown in Figure 3-11.

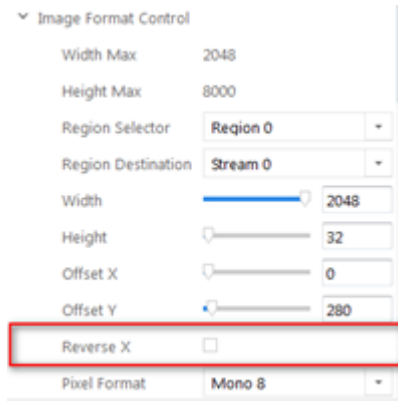

Figure 3-11 Mirroring Function

3.3.6 White Balance

The camera supports the white balance. The white balance refers to the camera color adjustment depending on different light sources. Adjust the Gain Value of the image’s R channel and B channel to keep white regions white under different color temperatures. Ideally, the proportion of R channel, G channel and B channel in the white region is 1:1:1.

Table 3-2 White Balance Status Introduction White Balance Status Introduction

Status	Description
OFF	MBW mode: You can adjust the R, G, and B gain value manually. The adjustable range is 1 to 4095, 1024 means the ratio is 1.0.
ONCE	Adjust the white balance value according to the current scene and the adjustment stops automatically after a while. The adjustment adopts a algorithm that looks for the gray blocks in the Bayer data.

Note:

The white balance adjustment is only available in color models.

Click Analog Control in the attribute list. Click Balance White Auto and Balance Ratio Selector. Select available white balance status parameter and finish setting, as shown in Figure 3-12.

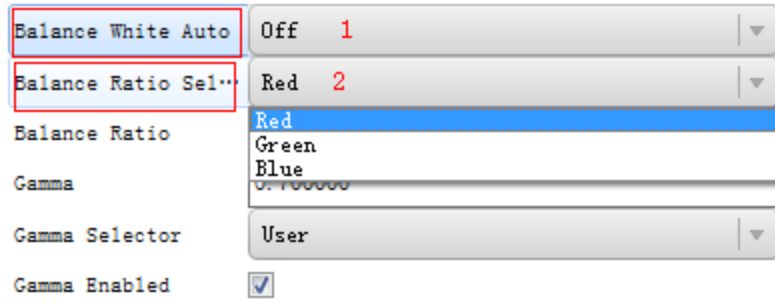

Figure 3-12 White Balance Setting

3.3.7 Region Setting of Auto Functions

Color camera can adjust exposure time and white balance automatically to achieve your expectations. By default, the camera will adjust the brightness and the white balance of the whole image. In addition, you can also set an area of interest, which is called AOI. The camera will adjust the AOI in the image. And the area outside the selected region will also be changed.

Regional exposure and regional white balance are generally used in the back light scene and the scene with the great difference of regional brightness. You can also select rectangle region. The camera will adjust the region's exposure and white balance to achieve the best image quality.

Click Analog Control in the attribute list. Select Auto Function AOI Selector. Choose AOI1 or AOI2. Adjust Auto Function AOI Width value and Auto Function AOI Height value and finish setting, as shown in Figure 3-13.

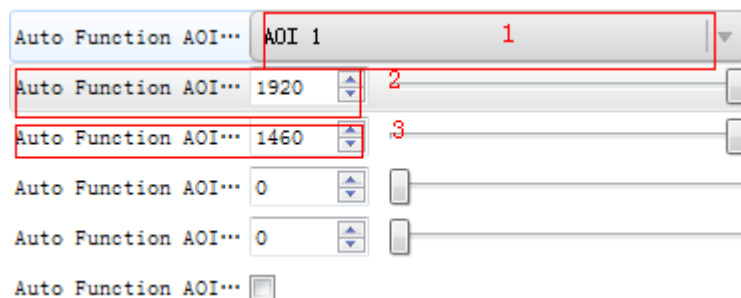

Figure 3-13 AOI Setting

3.3.8 Test Pattern

Click Image Format Control in the attribute list. Select Test Pattern and set the parameter. The default test pattern is OFF, as shown in Figure 3-14.

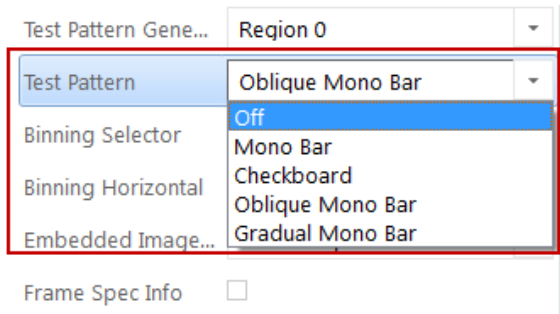

Figure 3-14 Test Pattern

The mono camera provides four test patterns, including Mono Bar, Vertical Color Bar, Horizontal Color Bar and Checkboard as shown in the following four figures.

Note: Color camera and black and white camera have different test patterns. The specific test pattern is decided by the camera function.



Figure 3-15 Mono Bar Test Pattern

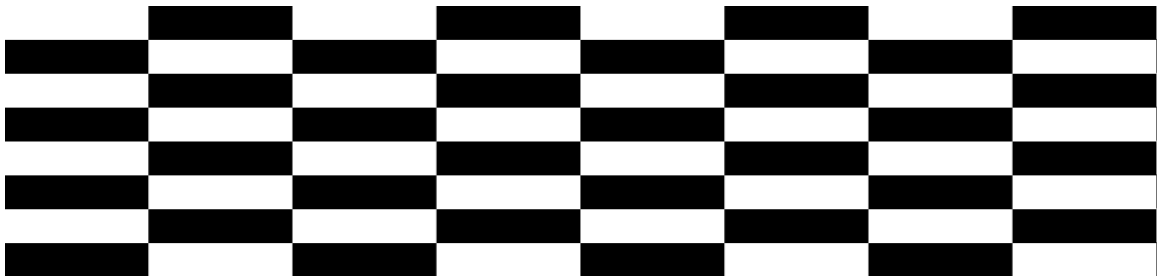

Figure 3-16 Checkboard Test Pattern

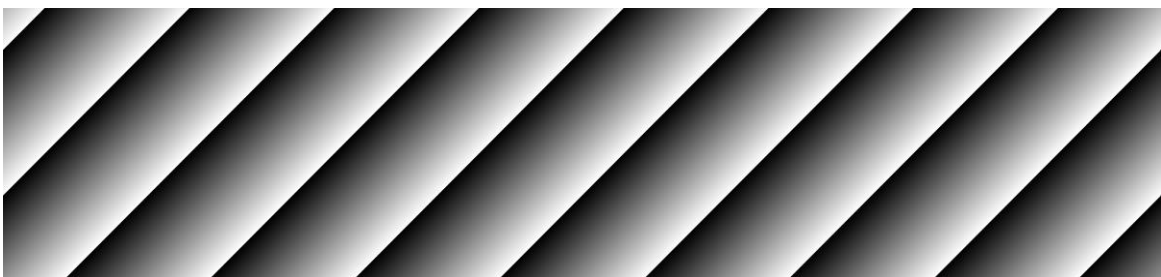

Figure 3-17 Oblique Mono Bar Test Pattern



Figure 3-18 Gradual Mono Bar Test Pattern

The color camera provides six test patterns, as shown below.

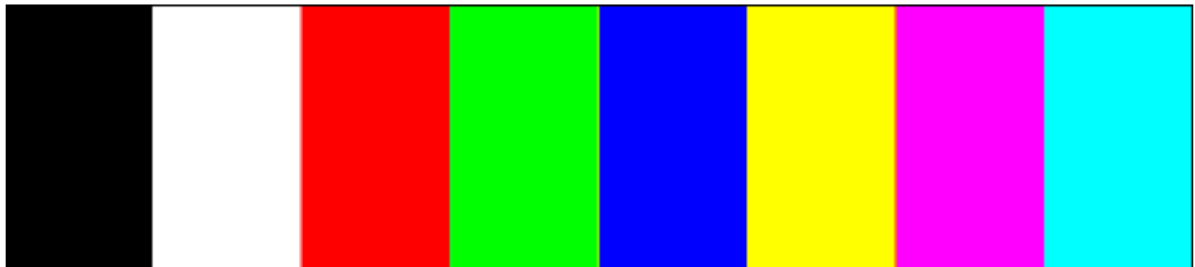

Figure 3-19 Vertical Color Bar Test Pattern



Figure 3-20 Mono Bar Test Pattern

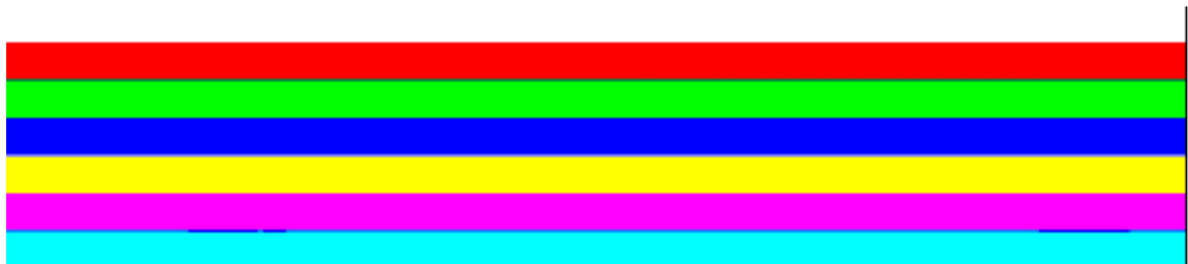

Figure 3-21 Horizontal Color Bar Test Pattern

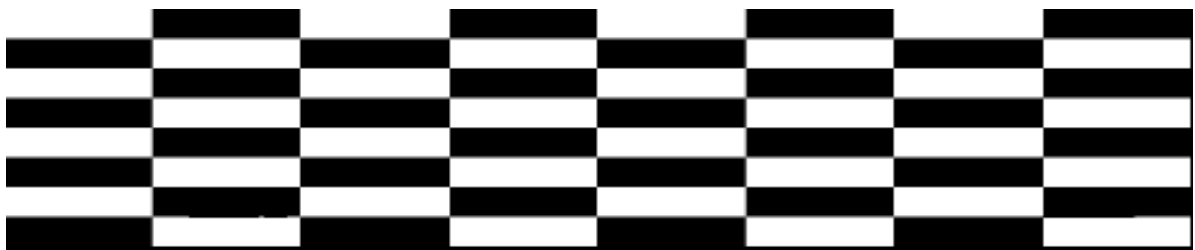

Figure 3-22 Checkboard Test Pattern

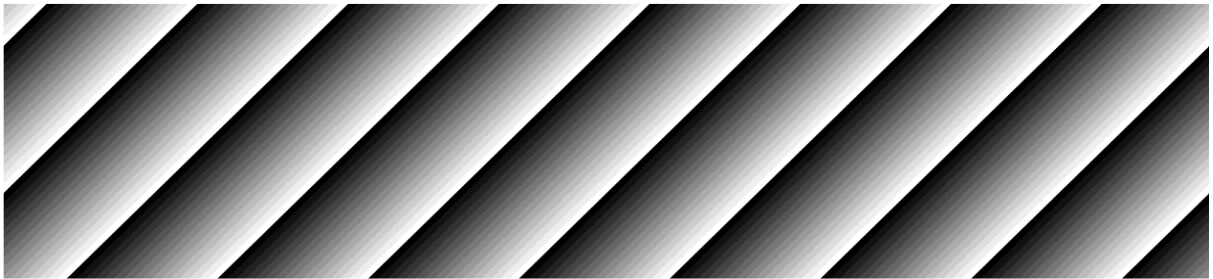

Figure 3-23 ObliqueMono Bar Test Pattern



Figure 3-24 Gradual Mono Bar Test Pattern

3.4 Image Acquisition and Transmission

Image acquisition mode is divided into internal trigger mode and external trigger mode. Internal trigger mode includes line acquisition mode and frame acquisition mode. External trigger mode includes software trigger mode and hardware external trigger mode.

Select On or Off in Trigger Mode to select either internal trigger mode or external trigger mode. (Off refers to the internal trigger mode and On refers to the external trigger mode.)

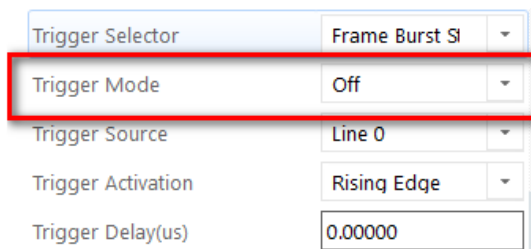

Figure 3-25 Trigger Mode Setting

3.4.1 Internal Trigger Mode

The Camera can output one image or several images continuously in the internal trigger mode.

Click Acquisition Control in the attribute list. Select Acquisition Mode and you will see elements of Continuous and SingleFrame. Continuous refers to outputting images continuously based on the configured frame rate. SingleFrame refers to outputting only one image, as shown in Figure 3-26.

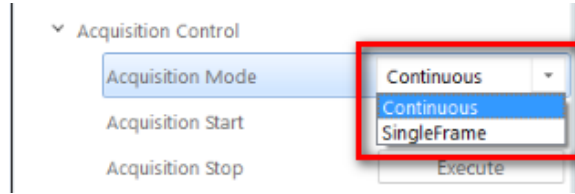

Figure 3-26 Internal Trigger Mode

3.4.2 External Trigger Signal and Working Mode

The signal for the camera to acquire external trigger signal includes the software trigger signal and the signal from external level.

Under the external trigger signal mode, the camera can output images according to single frame mode, burst mode, PWM mode and any other working modes.

- Software trigger mode

Support software trigger mode. When setting software trigger mode, the client software will send command to the camera to capture and transfer images by gigabit network.

Click Acquisition Control in the attribute list and select Trigger Mode. Choose On to open trigger mode. Select Trigger Source and choose Software to switch to the software external trigger status. Click Execute in Trigger Software to trigger image acquisition, as shown in Figure 3-27.

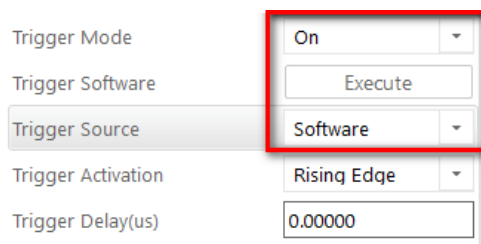

Figure 3-27 Software Trigger Mode Setting

- Hardware external trigger mode

Select Trigger Source and Choose Hardware to switch to the hardware external trigger status.

(1) Trigger edge selection

Selecting Rising Edge/Falling Edge/High Level/Low Level under the external signal is available.

(2) Trigger delay

As shown in Figure 3-28, in order to integrate later, the camera can set delay time when receiving the trigger signal. As shown in Figure 3-29, the delay time can be set through Trigger Delay. The range is from 0 to 32000000 and the unit is μs .

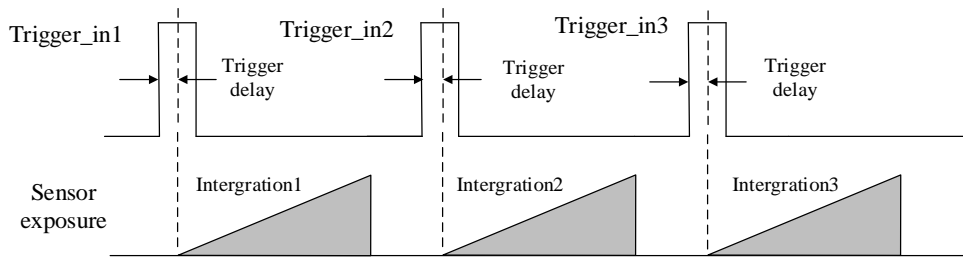

Figure 3-28 Signal Delay Principle

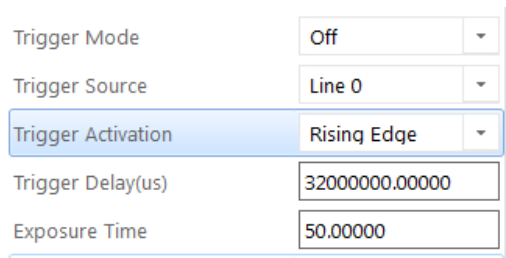

Figure 3-29 Delay Time Setting

(3) Triggering Anti-jitter

The noise may exist in external trigger's input signal and it may cause spurious triggering status if it goes into the camera. Thus the debounce is necessary.

The debounce parameter can be set through Line Debouncer Time in the client software. The unit is μs . The timing sequence map is shown in Figure 3-31. The camera will ignore the trigger signal if the debouncer time is longer than the triggering signal time.

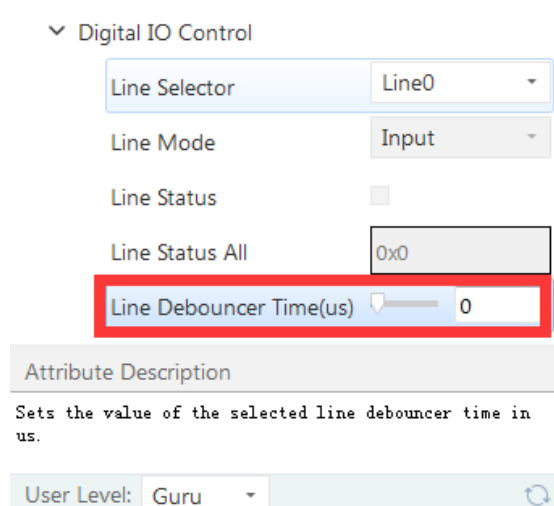

Figure 3-30 Line Debouncer Time Setting

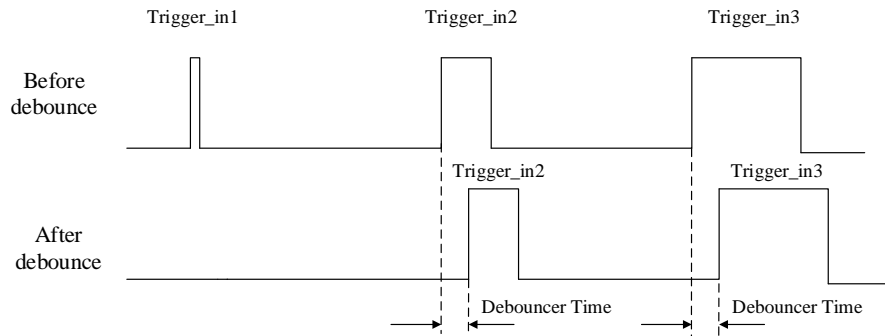

Figure 3-31 The Debounce of Triggering Input Signal Sequence Map

3.5 Strobe Output

Strobe is external trigger output signal and is used for controlling external devices such as flashing light and so on. You can set the Strobe polarity, duration, output delay and pre-trigger through the client software.

As shown in Figure 3-32, click Digital IO Control. Select Line Selector and choose output pin. Check Strobe Enabled and finish setting.

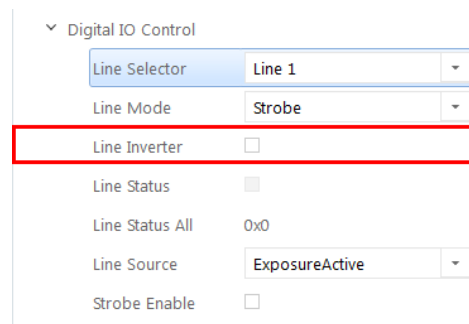

Figure 3-32 Strobe Output Mode

Note:

By default, Line 1 and Line 4 are used as signal output pins. Line 2 is a configurable input and output pin. If Line 2 output is to be strobe, the Line 2 pin must be configured as an output pin at Digital IO Control.

3.6 Acquisition Mode under External Trigger

3.6.1 Acquisition Start and Stop

The acquisition start and stop commands are used to control camera image acquisition. Before acquiring the image, you must issue the acquisition start command. When the acquisition stop command is issued, if the camera is in the acquisition process, the image acquisition will be stopped after current acquisition. Otherwise, the acquisition will stop immediately.

3.6.2 Acquisition Mode

The acquisition mode of the line scan camera includes single frame acquisition and continuous acquisition.

Single Frame, the camera must acquire the image after receiving the acquisition start command. After collecting one frame, the camera will not continue the acquisition unless sending the acquisition start command.

Continuous, after the acquisition command is received, the camera will output an image every frame trigger or line trigger. The camera will keep acquiring the image continuously and stop the image acquisition until the acquisition stop command is issued.

3.6.3 Trigger Mode

In the external trigger mode, the acquisition mode is divided into standard free trigger, line trigger, frame trigger and line plus frame trigger mode. For the system, when $V + > V -$, the data system reads is positive. When $V + < V -$, the data system reads is negative. In the actual project application, the sensor power supply must be 5V, same as the line sacn camera interface voltage level. At the same time pay attention to whether the sensor is differential signal type, connection of ingle-ended and differential signal line is different. (The differential signal is more stable than the single-ended signal).

The relationship between the input trigger signal, strobe output signal, camera exposure time and readout time in each mode is as follows:

(1) Free Trigger Mode

Line trigger and frame trigger are in the off state of the trigger mode, in the Acquisition Mode option box, if you select Continuous, the camera continues to output the image at the currently set frame rate, in SingleFrame exposure mode only in the case of manually click on the Acquisition Start will aquire image, and not continuous. The triggering signals of the above modes are generated by the camera itself, and the user can adjust the line frequency parameters according to the demand, as shown in Figure 3-33.

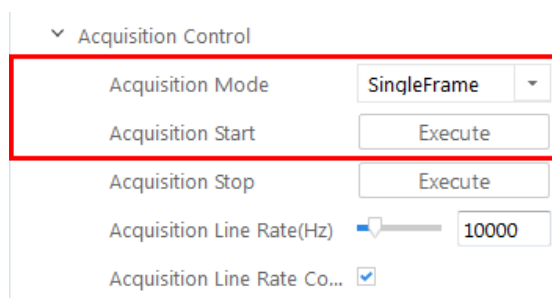

Figure 3-33 SingleFrame Trigger Mode

(2) Line Trigger Mode

Line Trigger On in the active mode, the frame trigger is off and the line frequency is determined by the frequency of the external line trigger control signal. In this mode, only one line is exposed when a trigger signal is input, as shown in Figure 4-34 and Figure 4-35.

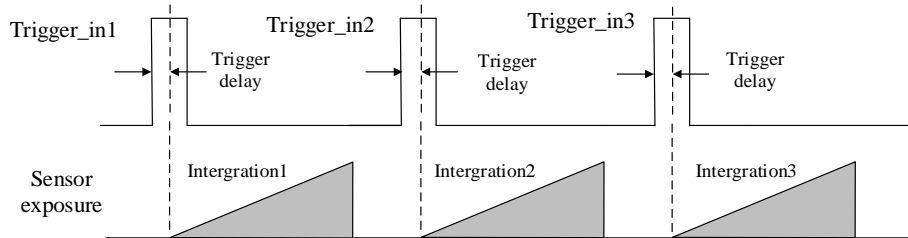

Figure 3-34 Standard Line Trigger Mode

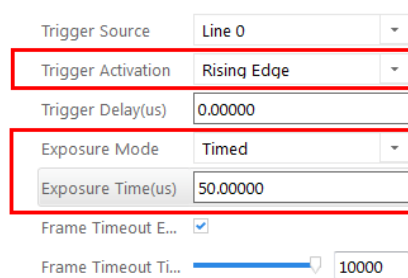

Figure 3-35 Trigger Setting

The selectable range of the trigger signal is Line0, Line2, Line3, axis encoded output and frequency converted output signal. It is also necessary to set the trigger to take effect on the rising edge or the falling edge of the trigger signal. When the corresponding trigger signal is set, the camera will capture the image with the corresponding trigger signal.

- **Rising edge**, refers to the rising edge of the trigger signal is valid, that is camera exposure and acquisition at the beginning of the rising edge of the trigger signal;
- **Falling edge**, refers to the falling edge of the trigger signal is valid, that is camera exposure and acquisition at the beginning of the falling edge of the trigger signal.

If the trigger frequency exceeds the camera limit, the camera cannot respond. The exposure time of the camera is selected by both timing and pulse width modes.

When the exposure mode select pulse width, the camera's exposure will be directly controlled by the line trigger signal. If the rising edge of the camera trigger setting is valid, the exposure time will start when the signal rises to fall, or vice versa, as shown in Figure 3-36.

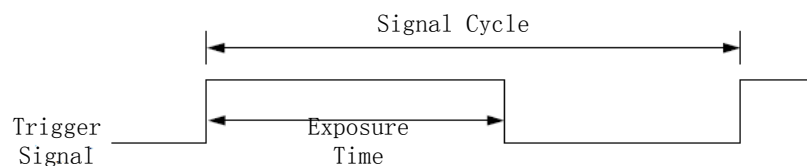

Figure 3-36 Pulse Width

When the exposure mode select timing mode, the line trigger exposure time selected by the setting exposure time parameters.

(3) Frame trigger mode

Line trigger off, frame trigger on. That is need for external frame trigger signal, set the frame height, no line trigger signal, line frequency can be set according to demand, mono line scan camera can be set from 1Hz-51kHz, color line scan camera can be set to a range of 1Hz-26kHz line frequency.

The frame trigger signal can be selected in software trigger, Line0, Line2, Line3 and frequency conversion output. When the trigger signal selects one of Line0, Line2, Line3 or frequency conversion output types, set the effective time corresponding to the corresponding trigger signal, as follows:

- **Rising edge**, means the rising edge of the trigger signal is valid, that is camera exposure and acquisition at the beginning of the rising edge of the trigger signal, and stops until a line signal that is sufficient to output a full frame is acquired.
- **Falling edge**, means the falling edge of the trigger signal is valid, that is camera exposure and acquisition at the beginning of the falling edge of the trigger signal, and stops until a line signal that is sufficient to output a full frame is acquired.
- **High level**, means the trigger signal is active high, that is, as long as the trigger signal is at high level, the camera will maintain the exposure acquisition state;
- **Low level**, means the trigger signal is active low, that is, as long as the trigger signal is low, the camera will maintain the exposure acquisition state.

The camera provides Frame Burst trigger mode, which receives a trigger signal to output multiple lines of image. The number of Bursts can be set by the client software through Acquisition Burst Frame Count, ranging from 0 to 1023. The frame trigger sequence diagram is shown in Figure 3-37. Burst Frame Count = 3, a trigger signal output three images. Strobe output control is equivalent to single frame trigger mode. Frame trigger time is determined by the line frequency and exposure time.

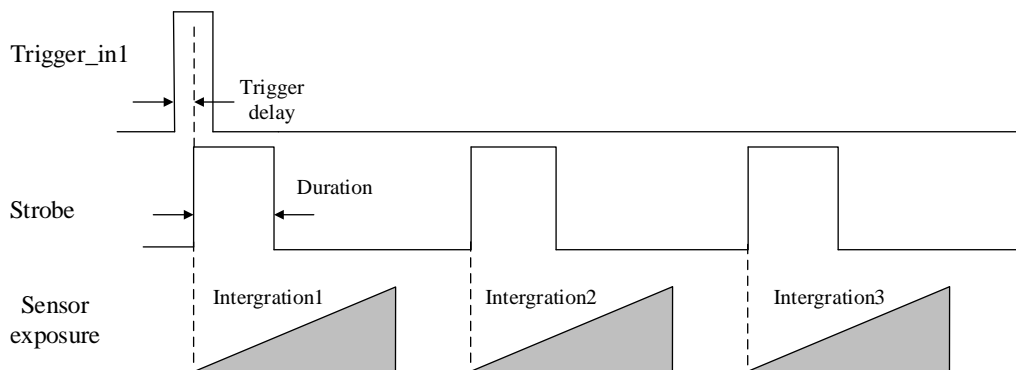

Figure 3-37 Frame trigger sequence diagram

(4) Line plus Frame trigger mode

This trigger mode is in the line trigger and frame trigger all in the On state, need for external frame trigger signal, line trigger signal and set the frame height. The number of lines in a frame is controlled by the frame height register, and the line rate is controlled by an externally supplied line trigger signal, while being limited by the internal setpoint. In the set exposure mode, output line will also be in accordance with the set frame rate output image, the specific trigger is similar to frame trigger mode.

In this mode, the camera's external frame trigger signal and line trigger signal is required. Only after the frame trigger signal arrives, the line trigger signal will work. The number of lines triggered by a frame is determined by the frame height register, and when a specified number of lines is not triggered, the new frame signal is discarded. The line trigger signal can always occur at one frequency cycle, or it can cycle change follow the frame trigger signal. The camera starts to detect the line trigger signal after receiving a frame trigger signal, exposes a line of image data according to the line trigger signal, and does not detect line trigger signal until the number of lines of the set frame height is reached. At this point the camera returns to the wait state for the frame trigger signal, and the frame signal before it is considered invalid. It should be noted that the number of line trigger signals between the previous frame trigger and the next frame trigger should be greater than or equal to the set frame height register value. Otherwise, the camera will not reach the frame rate you want.

Frame Timeout Time, can be set in the range of 58 to 10000 microseconds, indicating that the image will be output regardless of whether it has accumulated to one frame within the set time.

3.7 Encoder Control

The camera is equipped with a shaft encoder control module that can accept both A and B channel encoder controller triggering. For example, the output signal of the module can be used as an input signal for camera line triggering or frame trigger.

3.7.1 Source Signal

Using the axis encoder module, you can receive two signals A and B which has a phase difference, after the internal operation of the module, the output signal can be used as camera trigger signal, as shown in Figure 3-38, Figure 3-39.

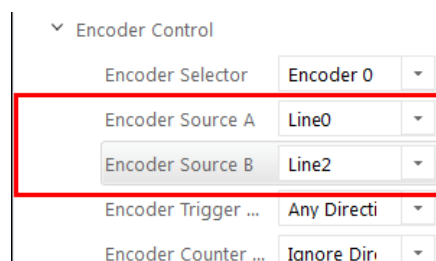

Figure 3-38 Source Signal Select

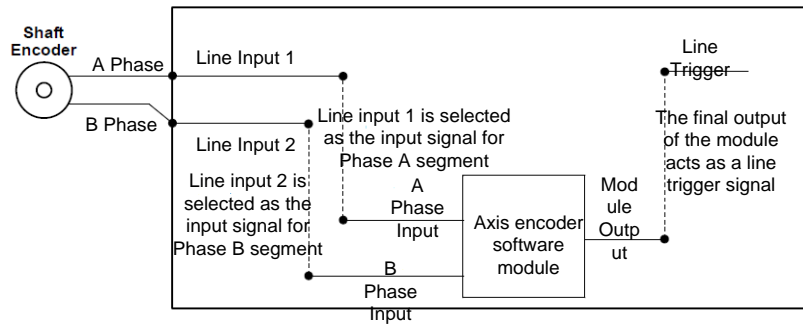

Figure 3-39 Functional implementation flow

3.7.2 Axis encoder control parameters

Trigger Direction

The triggering direction of the source signal can be selected in any direction or forward direction, as shown in Figure 3-40.



Figure 3-40 Trigger Direction

Axis Encoder Counting

Axis encoder can choose to ignore direction count and fixed direction counting mode, that is ignore direction counting will record the data of all the direction; fixed direction counting will only record the data of forward once, repeated data is not recorded. And select to set the limit value of counting (0 ~ 32767). After reaching the limit value, it will be cleared automatically or direct cleared manually, as shown in Figure 3-41 and Figure 3-42.

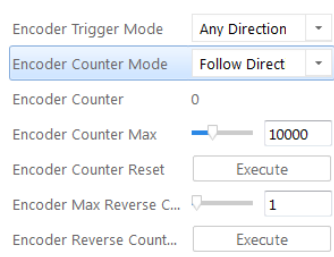

Figure 3-41 Encoder Counting

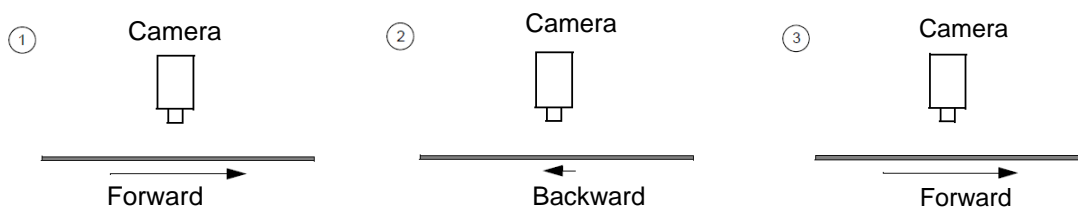

Figure 3-42 Counting Description

When set to ignore the trigger direction, then the trigger will be counted regardless of whether it is forward, reverse or repeated. When the trigger direction is set to positive, the positive trigger will count once when forward direction, and the count of the reverse trigger is negated by zero.

The advantages of the shaft encoder are:

- Encoder output pulse frequency is proportional to rotating speed;
- The output pulse acts as a trigger signal for line scan camera;
- Synchronous acquisition speed and sample movement of camera;
- Non-uniform motion can also be a perfect match;
- A trigger signal can be set to capture multiple lines or multiple frames, adjustable ratio.

3.8 Frequency Converter Control

The camera has a frequency conversion function which allows the frequency of the camera signal to be triggered to be different from the frequency of the desired input signal. The module's input signal can be one of the three line input signals, or it can come from the axis encoder module. As shown in Figure 3-43.

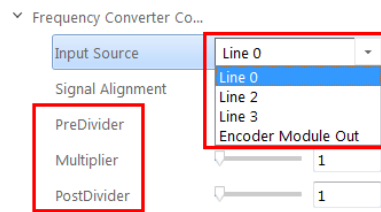

Figure 3-43 Source Signal Select

In the frequency conversion module contains three sub-sequence in turn act on the source signal, respectively, PreDivider, Multiplier and PostDivider.

PreDivider

The input signal first enters into the PreDivider module, which divides the whole signal by the integer, and reduces the frequency of the source signal, and sends the processed signal to the Multiplier module.

The PreDivider module reduces periodic jitter on the input signal, and signals above 100 kHz must pass through the PreDivider to reduce the frequency because the Multiplier can only accept signals in the 10 to 100 kHz frequency range. The periodic jitter of the signal from the axis encoder can be accepted.

Multiplier

When the signal is processed by the PreDivider, it is sent to the Multiplier. The Multiplier multiplies the signal by an integer to increase the signal frequency. The signal is then sent to the PostDivider block.

Adjustment parameters can be set to rising or falling edge. If a rising edge is set, each rising edge of the signal coming from the PreDivider will be locked to match the signal of the rising edge, and vice versa.

Be sure not to use too many multipliers to increase the frequency of the signal and to avoid trigger signal frequency beyond the maximum supported line frequency of the camera. Even if a smaller multiplier is selected, an excessively high frequency may be generated in the frequency adjustment, exceeding the maximum line frequency of the camera.

PostDivider

PreDivider reduces the frequency of the signal by an integer factor and uses the resulting new frequency signal as the camera's trigger signal.

Signal processing after these three modules as the camera's final trigger signal.

3.9 I/O Electrical Character

3.9.1 Practical Wiring

(1) Differential Input

Used as a differential signal: The differential IO of the camera should be connected positive to positive, negative to negative to the sensor.

Used as a single-ended signal: The positive of input differential signal line connect to user's signal line, the negative of differential signal to be left hang (must not be in the hang on state, or cannot be used)

In the client, tick the Line Status status as single-ended and untick for differential, as shown in Figure 3-44.



Figure 3-44 Line Status

(2) Differential Output

Used as a differential signal: Positive to positive, negative to negative.

Use as a single-ended signal: Use one of these signals, and the positive signal is complementary to the negative signal.

3.9.2 Line0/Line3 Input Circuit

The camera has two input pins, Line0 and Line3. The input signal line is connected to the camera via a 12-pin power and IO line. This input accepts RS-422, RS-644 and LVTTTL standards.

- RS-422 Standard Input

Line0, line3 interface circuit features using RS-422 standard, as shown in Figure 3-45. In order to ensure the normal operation of the camera's input circuit, you need to connect the camera ground signal to the external ground signal.

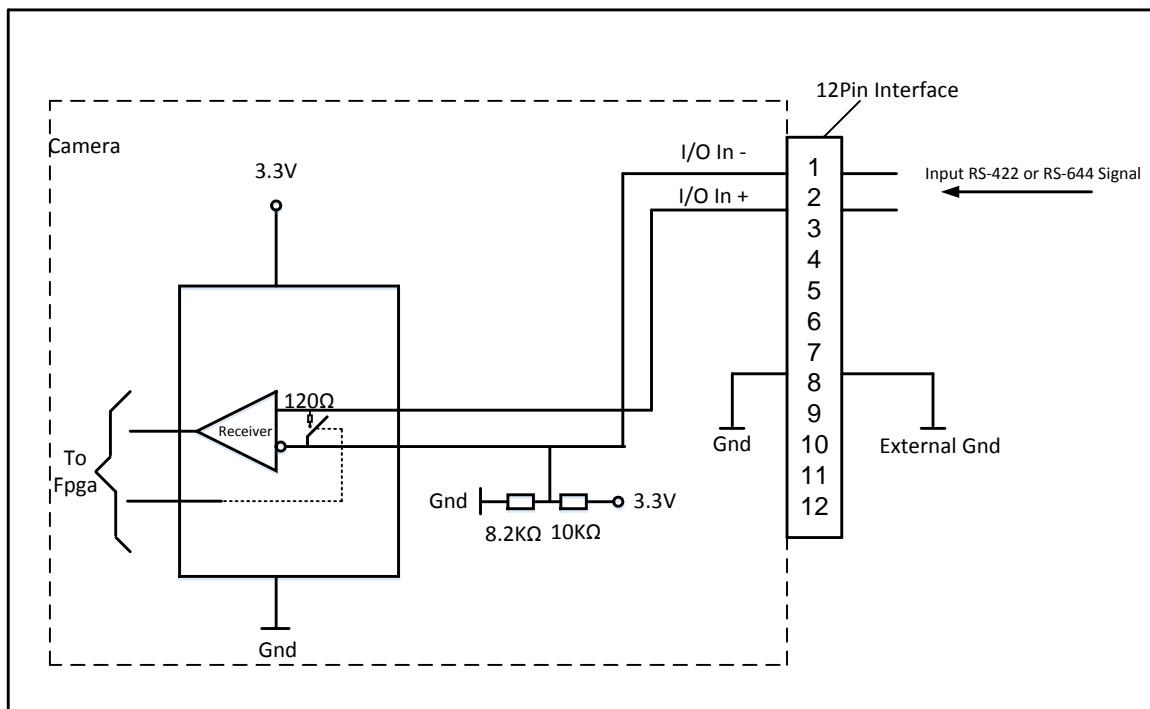

Figure 3-45 Input RS-422 or RS-644 Signal

The RS-422 standard defines the connection of the bus structure. Several different camera inputs can be connected to the RS-422 bus as shown in Figure 3-46.

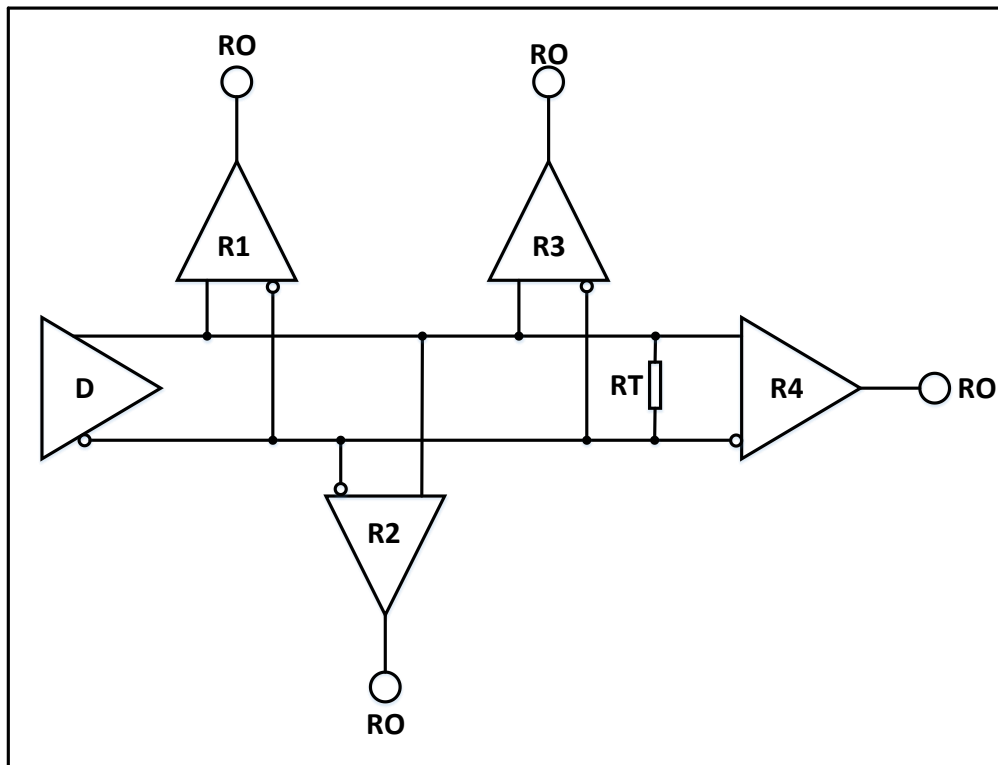

Figure 3-46 Four receive RS-422 bus topologies

Up to 10 cameras can be connected at the same time in this bus structure, with only one camera being the "master" transmitter (D) and the other camera being the "slave" receiver (R). The trace length between the receiver and the bus should be as small as possible. The bus must have a 120Ω terminating resistor (RT).

When a camera is on the bus as the last receiver, the camera's termination resistor should be enabled, and the rest of the cameras' termination resistors should be disabled. Multiple termination resistors should not be enabled on the bus. This reduces the reliability of the signal and can cause damage to the RS-422 device.

- RS-644 Standard Input

If the camera's input is routed to RS-644 standard, the input must have a 120Ω termination resistor.

- LVTTTL Standard Input

If the camera input can accept the LVTTTL standard, the signal connections are shown in Figure 3-47.

The following table lists the electrical requirements for access:

Table 3-3 LVTTTL Input electrical Characteristics Requirements

Voltage	Definition
---------	------------

+0V—+5.0V	Recommended operating voltage
+0V—+0.8V	The voltage represents a logic 0
+0.8V—+2.0V	The region in which the transition threshold occurs, there is no defined logic state
大于+2V	The voltage represents a logic 1
+6.0V	The maximum voltage beyond which the camera may be damaged

When the input is LVTTTL standard, the 120Ω termination resistor at the input needs to be disabled.

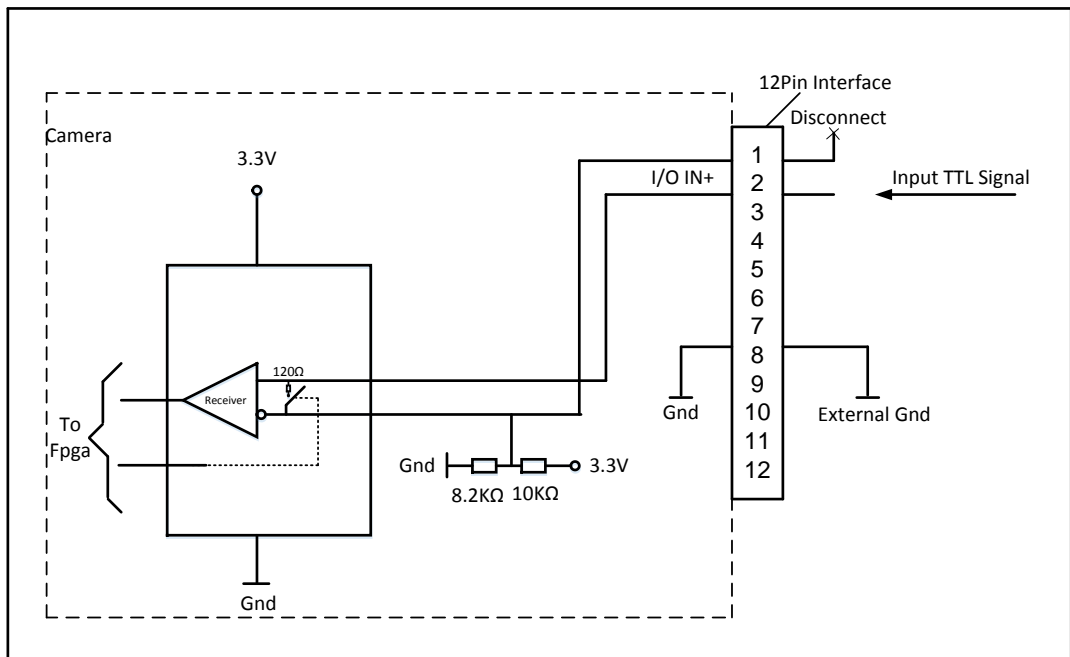

Figure 3-47 Signal connection to LVTTTL

3.9.3 Line1/Line4 Output Circuit

The camera has two output pins, Line1 and Line4. The output signal line is connected to the camera via a 12-pin power and IO line. This pin can output RS-422 signal, also compatible with RS-644 standard or LVTTTL standard.

- RS-422 Standard Output

In order to ensure the normal operation of the camera's output circuit, you need to connect the camera ground signal to the external ground signal.

This interface can be used as a "master" transmitter, connected to the RS-422 bus mentioned above, as shown in Figure 3-48.

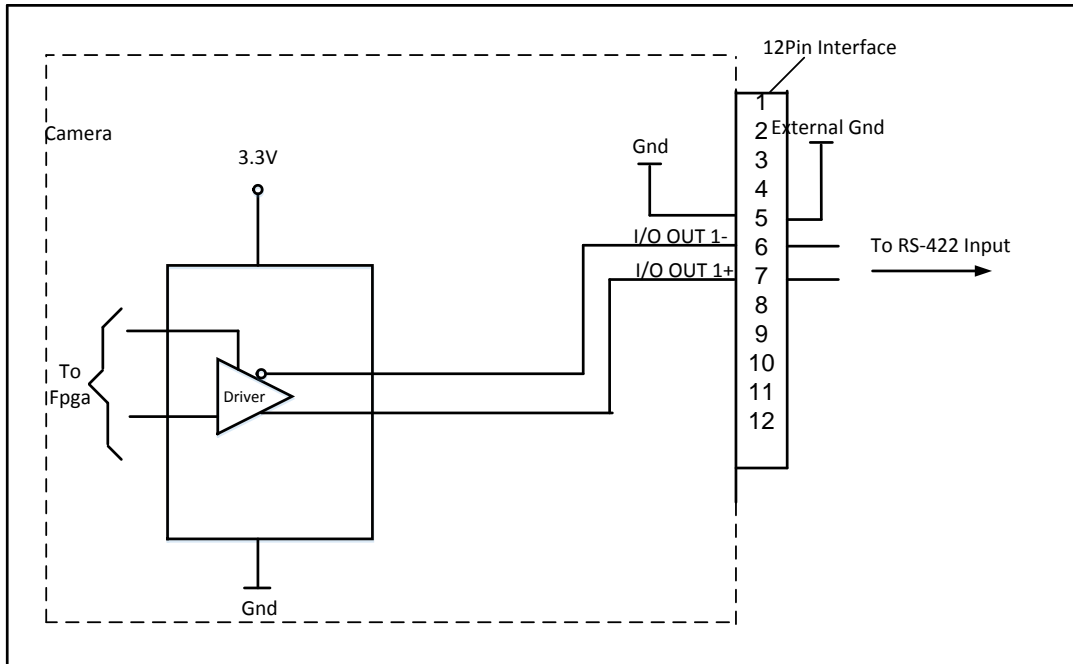

Figure 3-48 Output RS-422 signal connection

● RS-644 Standard Output

The camera's RS-422 standard output signal can not be directly connected to the RS-644 standard. When connecting the output to the RS-622 standard input, it is necessary to add the resistor network shown in Figure 3-49 at the camera's output position. In order to ensure the normal operation of the camera's output circuit, you need to connect the camera ground signal to the external ground signal.

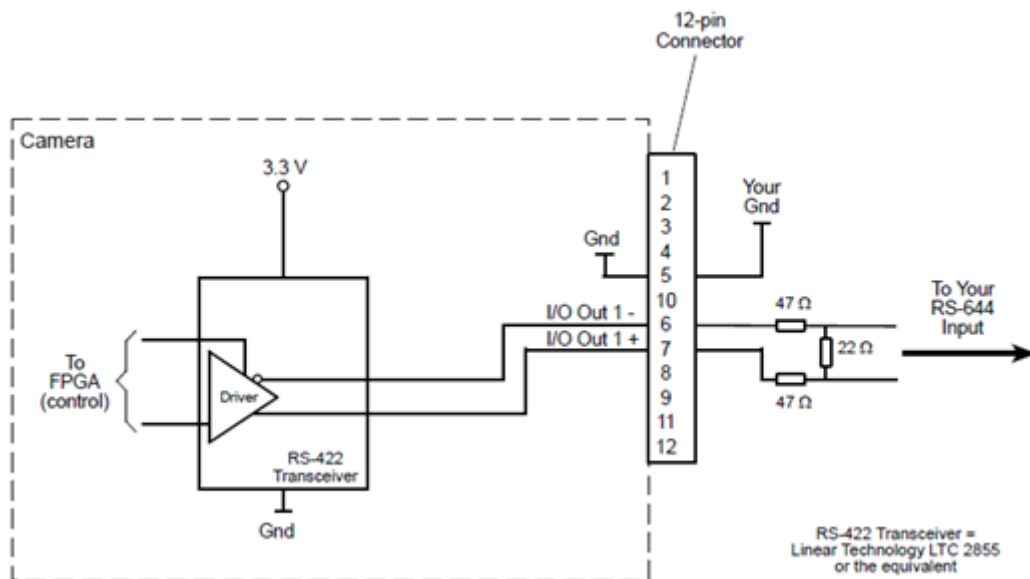

Figure 3-49 Output RS-644 signal connection

● LVTTTL Standard Output

To use the LVTTTL standard as the output signal, the wiring shown in Figure 3-50 is required.

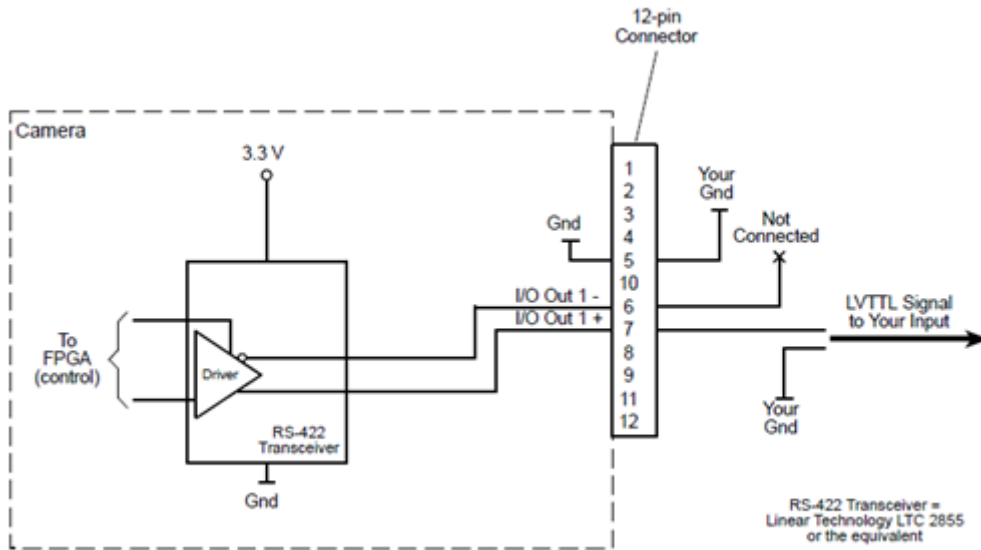

Figure 3-50 Output LVTTTL signal connection

3.9.4 Line2 Configurable Bi-direction I/O Circuit

In controlling I/O, the configurable bi-direction non-isolated IO circuit of Line2 can be shown in Figure 3-51.

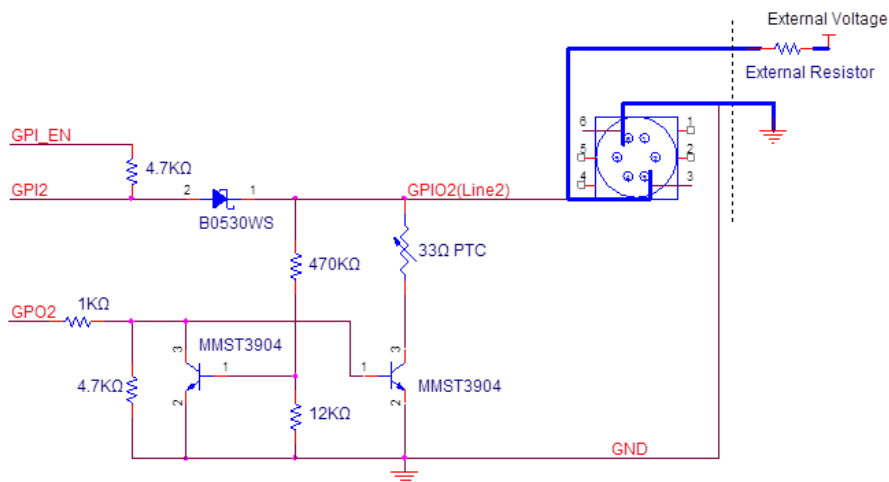

Figure 3-51 Line2 Bi-direction I/O Circuit

1. Configure Line2 to input pin

Logic 0 input level: 0~0.5VDC (GPIO2 pin)

Logic 1 input level: 1.5~30VDC (GPIO2 pin)

Please make sure the input voltage is not from 0.5V to 1.5V as the electric status among the two values is not stable.

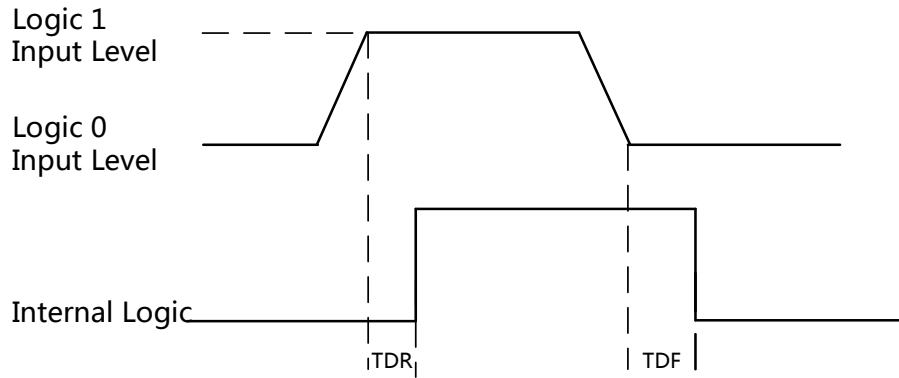

Figure 3-52 Inputting Logic Level

Please connect to GND pin first to protect GPIO pin and then input voltage to Line2 pin.

2. Configure Line2 to output pin

The available maximum current is 25mA and the output impedance is 40Ω.

When the environment temperature is 25 degree centigrade, the relationship among external voltage, impedance and the output low level can be shown in Table 3-4.

Table 3-4 The Parameter of Output Logic Low Level

External Voltage	External Resistor	VL (GPIO2)
3.3V	1KΩ	160mV
5V	1KΩ	220mV
12V	1KΩ	460mV
24V	1KΩ	860mV
30V	1KΩ	970mV

When the external voltage of 1KΩ external resistance turns to 5V, features of output logic level and electric feature in GPIO2 configuration can be shown in Figure 3-53 and Table 3-5.

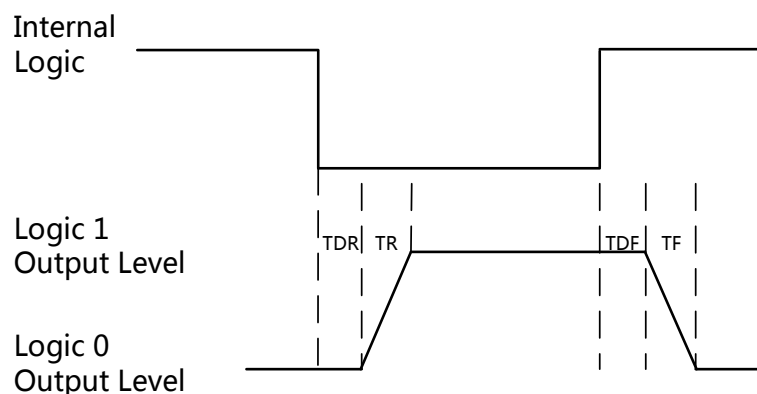

Figure 3-53 Output Logic Level

Table 3-5 Output Electric Feature

Parameter	Symbol	Value
-----------	--------	-------

Output Logic Low Level	TR	0.06us
Output Logic High Level	TF	0.016us
Output Rising Time	TDR	0.03us
Output Falling Time	TDF	0.28us

3.10 Transport Layer Control

3.10.1 DHCP and Persistent IP

The camera supports connecting with PC through DHCP or Persistent IP. As shown in Figure 3-54, the camera will acquire IP according to the following order.

1. If the camera's Persistent IP is available and the configured Persistent IP is available, the camera will load this Persistent IP. Or execute (2).
2. If DHCP function is available and the acquired IP address is available, the camera will load IP address that acquired by DHCP. Or execute (3).
3. Acquire LLA.

Figure 3-54 IP Address Configuration

Note:

Camera IP configuration needs to be set in the IP configuration tool, specific please refer to section 2.2.1.

3.10.2 Efficient Bandwidth and Setting

Packet Size and Packet Delay control the 1000M Ethernet's actual bandwidth. The theoretical calculation of 1000M network port's image loading bandwidth is:

$$\text{BandWidth} = ((\text{PacketSize} - (\text{IP} + \text{UDP} + \text{GVSP Header})) / (\text{PacketSize} + \text{MACHeader} + \text{CRC} + \text{Packet-Delay})) * 1000\text{M}/\text{bps}.$$

Normally, IP/UDP/GVSP Header takes 36 bytes. MAC Header takes 14 bytes. CRC takes 4 bytes. Taking setting Packet Size 1500 and Packet Delay 400 as an example, the actual network bandwidth is

$$\text{BandWidth} = (1500 - 36) / (1500 + 14 + 4 + 400) * 1000\text{Mbps} = 759.36 \text{ Mbps}$$

The actual network bandwidth is smaller than the theoretical one because of the network message, GVCP, GCSP leader, Trailer and any other overheads.

Set Packet Size (GEV SCPS Packet Size) value and Packet Delay (GEV SCPD) value by using the slider and the input box. You can set these two parameters according to the computer performance and the network card performance in the condition of no data package loss, as shown in Figure 3-55.



Figure 3-55 Packet Size Setting And Packet Delay Setting

3.10.3 Parameters Saving and Loading

The camera can save four groups of parameters, including one group of factory parameter and three groups of configurable parameters. You can save currently configured parameter and set corresponded default parameter when logging in at next time in User Set Control in the attribute list.

Configuration method: Select one of the parameter names in the drop-down box in User Set Selector. Save current parameter setting. In the drop-down box of User Set Default, select one of the parameters when the client runs, as shown in Figure 3-56. Click Execute in both User Set Save and User Set Load.

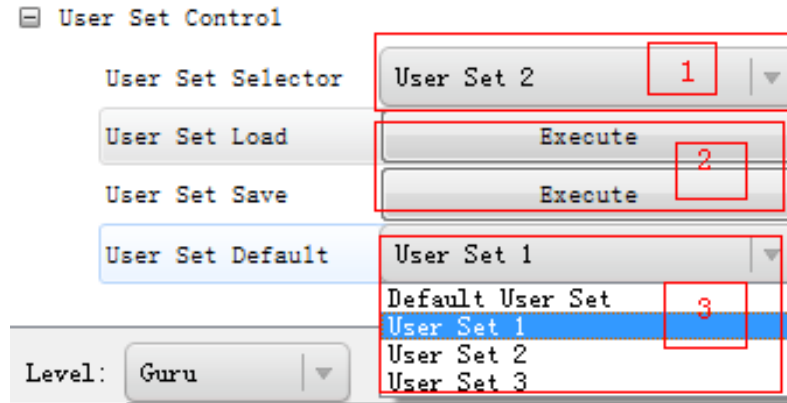

Figure 3-56 Parameters Saving And Loading

Figure 3-57 shows the relationship among four groups of parameters.

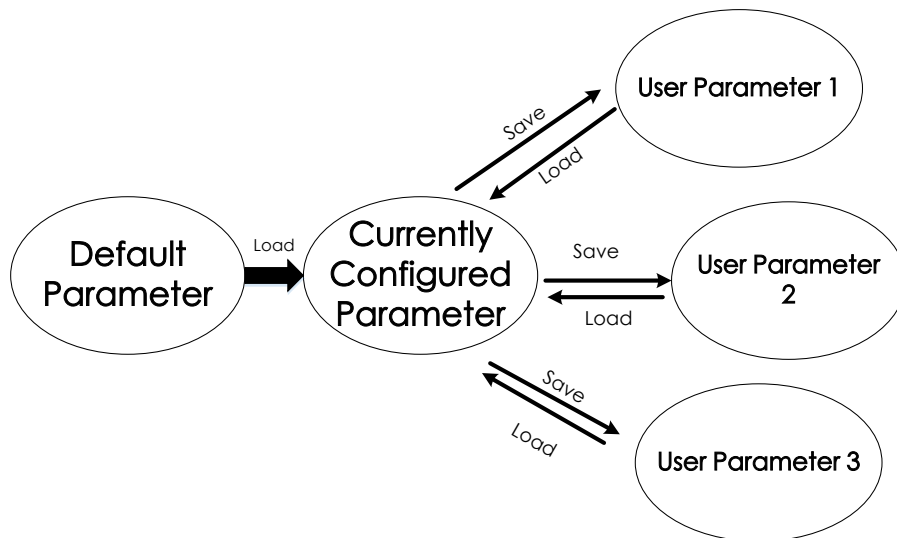

Figure 3-57 The Relationship Among Four Groups of Parameters

3.10.4 Embedded Information

The camera supports embedding information into the image data. The current supporting embedded information is:

- Timestamp
- Analog gain
- Exposure time
- Average brightness
- White balance gain
- Frame number
- Trigger counter
- ROI

The above eight information will be embedded in the image data one by one according to the client. If the information is not available, it will not be embedded.

The AOI will not affect the embedding. If the region of AOI is small, the first line of the image data is not enough for embedding. Then the information will be embedded in the second line.

Each embedded information of the available data will be put in the least 8 significant bits (No matter in MONO8 or RGB24).

The Embedded information is as following:

Timestamp: Take four bytes: transmission with four available data.

Data format: The data format of the timestamp is shown in Figure 3-58.

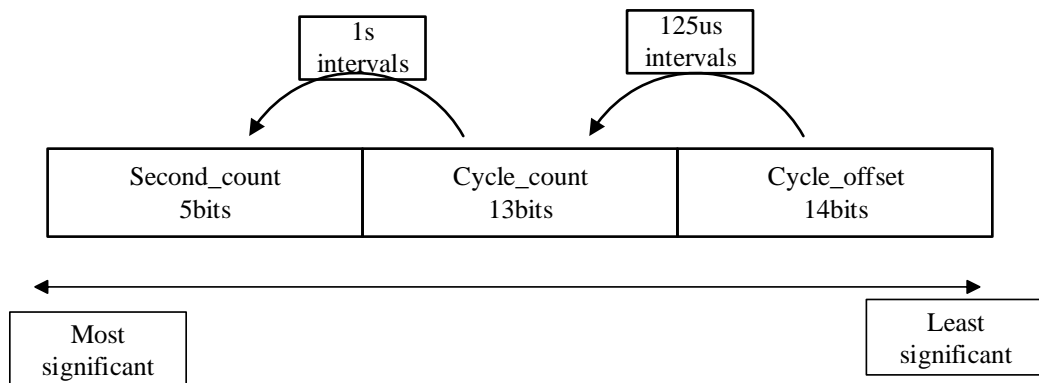

Figure 3-58 Timestamp Format

Analog gain: Take four bytes: transmission with four available data. Connect the least significant 8 bit of the four data together.

The data format of analog gain: Show the connected data directly. The range is form 0 to 1023. The Most Significant Bits will complement 0 automatically.

Exposure time: Take four bytes: transmission with four available data. Connect the least significant 8 bit of the four data together.

The data format of the exposure time: The connected least significant 8 bit of the four data is the number of the exposure line. Multiply the line number to 25.8μs. The result is the exposure time. The unit is μs.

Average Brightness: Take four bytes: transmission with four available data. Connect the least significant 8 bit of the four data together.

The data format of the average brightness: Show the connected data directly. The range is form 0 to 4095. The Most Significant Bits will complement 0 automatically.

White balance gain: Contains three components of gain. It consumes 8 bytes in total, including two bytes for R channel of Gain, two bytes for G channel of Gain and four bytes for B channel of Gain. In other words, the transmission uses eight available image data.

Data format of white balance gain: Each channel consumes 2 bytes. The range is form 0 to 4095.

Frame number: Take four bytes.

Frame number format: Connect four bytes directly. The range is form 0 to 2^{32} .

Trigger counter: Take 4 bytes. The range is from 0 to 2^{32} .

ROI: Take three bytes in the initial position. The length and the width consume three bytes.

The data format of ROI:

(1) The initial position of ROI takes three bytes. The length and the width consume three bytes.

(2) The initial coordinate of ROI' column takes one and a half bytes. The initial coordinate of ROI's row takes one and a half bytes. The column coordinate is in the front of the row coordinate. The coordinate of the length and the width also consume one and a half bytes respectively.

Click Image Format Control in the attribute list. Select Embedded Image Info Selector. Choose the parameter in the drop-down box and finish setting, as shown in Figure 3-59.

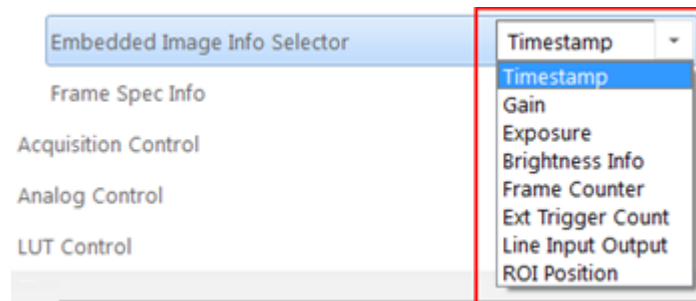

Figure 3-59 Embedded Information

3.11 Firmware Updating

Support firmware updating via LAN. After selecting available device in the device list, open Tool>Firmware Updating Tool in the Menu. Select available firmware updating kit, as shown in Figure 3-60.

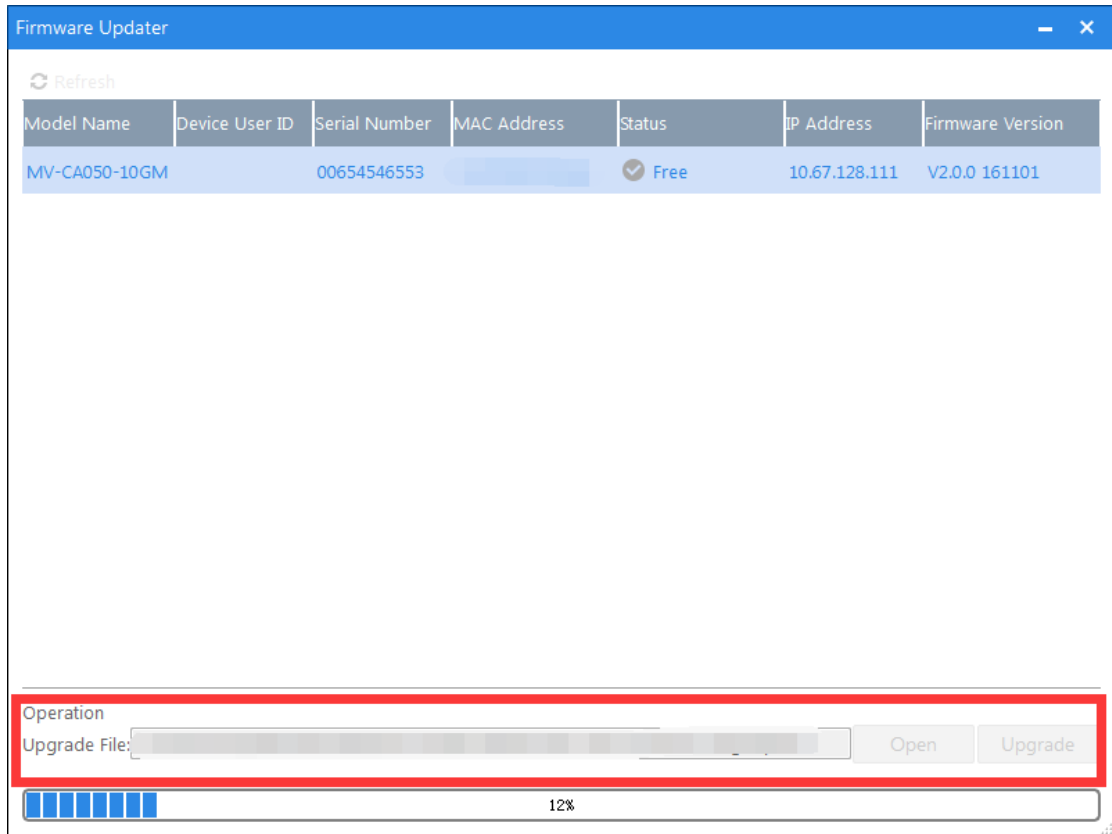

Figure 3-60 Firmware Update

Chapter 4 Troubleshooting

4.1 Indicator Status Definition

Table 4-1 LED Indicator Status

LED Status	Definition
Steady On	The LED indicator keeps lights on all the time
Unlit	The LED indicator keeps unlit all the time
Fast Flicker	The LED indicator flickers every 200ms to 300ms
Slow Flicker	The LED indicator flickers every 1000ms.
Extreme Slow Flicker	The LED indicator flickers every 2000ms.

4.2 Indicator Status Description

Table 4-2 LED Status Description

Indicator Status		Camera Status
Indicator in Red	Indicator in Blue	
-	-	The camera is off or hardware damaged.
-	Steady On	The camera is starting up.
Fast Flicker	-	Uboot loading failed.
Extreme Slow Flicker	-	IP address confliction or connection error
-	Slow Flicker	Idle while the camera is in the internal trigger mode.
-	Fast Flicker	Transmitting image while the camera is in the internal trigger mode.
	Extreme Slow Flicker	Transmitting image while the camera is in the external trigger mode.
The indicator flickers red and blue alternately every 1 second.		Upgrading the firmware.
Slow Flicker	-	Camera works normally but is not able to transmit data.
Steady on	-	Upgrading the firmware failed. Contact the technical support.

4.3 FAQ

Table 4-3 FAQ

No	Problem Description	Possible Reasons	Solutions
1	1. The camera cannot be detected by the client software. 2. The camera is detected by the client software but connecting failed.	1. The camera does not work properly. 2. The network cable is disconnected. 3. The camera and the PC that runs the MVS client software are not in the same subnet.	1. Confirm if the power supply of camera is well connected (via LED indicator), and the network connects properly (via network interface indicator). 2. Use MVS IP Configurator to detect the camera and change the IP address. 3. Confirm if the GenICam and network Filter driver are installed on the PC.
2	The camera is in read-only status.	The camera is connected with another client software.	Plug out the network cable, and replace it 3 seconds later.
3	The live view of camera is black.	1. The iris is closed. 2. Camera error	1. Open the iris. 2. Reboot the camera.
4	Camera cannot be triggered	1. Incorrect cable connection. 2. The camera works in the internal trigger mode	Make sure the trigger mode is correct and the external trigger is well connected.
5	The live view and image is normal, while the image saved could not be displayed properly.	The image format mismatches.	Make sure the image format what you saved is supported.